

AirWash[®] *plus*

Automatic Dip and Rinse System

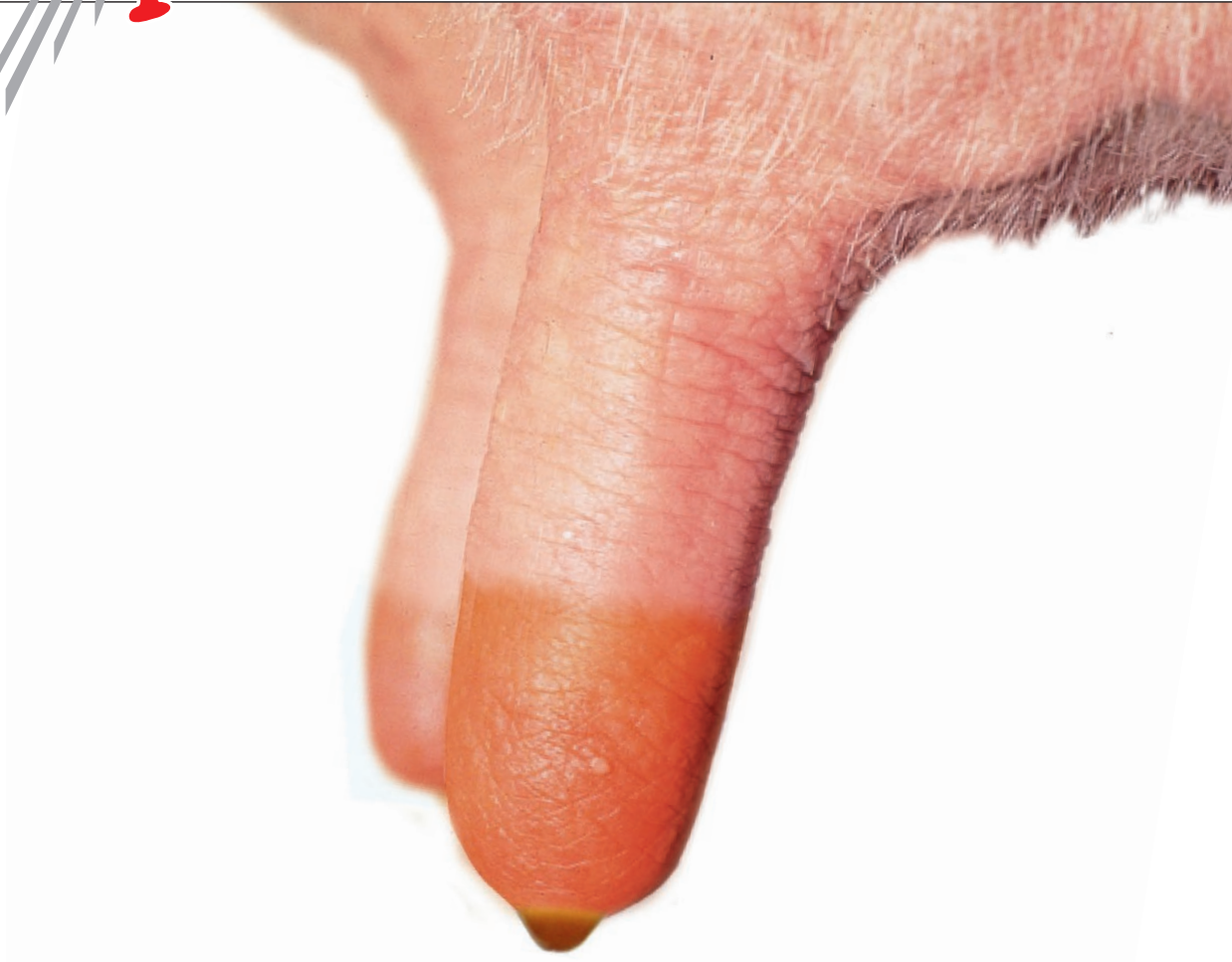

Manual version 2.4

1. Copyright

Copyright in this publication: Dutch Research & Innovations BV.

2. Disclosure

All rights reserved. No part of this publication may be reproduced, stored in a retrieval system, or transmitted, in any form or by any means, electronic, mechanical, photocopying, recording and/or otherwise without the prior written permission of DRI bv.

3. Limitations of use

This book may not be lent, resold, hired out or otherwise disposed of by way of trade in any form of binding or cover other than that in which it is published, without the prior consent of DRI bv.

4. Enquiries and amendments

All enquiries regarding comment, correction or amendment to this publication should be addressed to Dutch Research & Innovations BV, Aalsvoort 66a, 7241 MA, The Netherlands.

5. Disclaimer:

- The AirWash Plus system is designed to apply a quantity of teat dip to the lower part of the cows teat. As cows teats are varying size and characteristics, if you suspect unsatisfactory coverage you must take manual precautions and contact your supplier.
- The AirWash Plus system must be used with a suitable iodine product containing 2400ppm of iodine or less. Latic Acid teat dips MUST not be used and will void all warranties.
- The start signal for AirWash Plus is taken from the cluster removal system, no responsibility can be taken for the failure of the start signal.
- If any malfunction is suspected take manual precautions and contact your supplier.

General information	4
Safety precautions	5
Airwash Plus Introduction	6
How does it work?	8
Schematic setup Main Components	11
Technical data.	14
Getting started	16
AWP Pump & Filter Cabinet (DRI-3902)	18
AWP Dosing Unit (DRI-1020)	21
AWP Main Control Unit (DRI-3903)	23
AWP Regular (DRI-3908).	26
AWP Pro (DRI-3909)	31
AWP Gold (DRI-3915)	36
AWP End Connection (DRI-1774).	41
AWP Injectors (DRI-526/524/522).	42
AWP Programme / Copy kit (DRI-8004)	44
AWP Programming	45
AWP Pre-operation	47
AWP Service instructions	48
Troubleshooting	50
Dosatron troubleshooting	53

The AirWash Plus system is designed to apply a quantity of teat dip to the lower part of the cows teat. As cows teats are of varying size and characteristics, if you suspect unsatisfactory coverage you must take manual precautions and contact your supplier.

The AirWash Plus system is only recommended to use DeLaval Proactive teat dip. Latic Acid and other teat dips MUST not be used and will void all warranties.

The start signal for AirWash Plus is taken from the ACR (9-30V), no responsibility can be taken for the failure of the start signal. Occasionally the ACR signal is delayed by the milking machine manufacturer, this should be set to zero, otherwise there will be less time for the dip procedure.

If any malfunction is suspected take manual precautions and contact your supplier. This type of equipment relies on the cluster being on the cow at the point the teat dip is applied and no guarantee can be made of this happening in all cases. It is important that operators carry out periodic checks to ensure the equipment is functioning correctly.

DRI bv uses high performance and modern engineering plastics in the construction of milking equipment. The materials chosen are the best available for any given application.

The plastics used in the AirWash Plus system have good resistance to hot water, acid and alkali milking machine detergents and disinfectants even at high temperatures.

However, chemical resistance can be affected by products containing ketones, chlorinated hydrocarbons, aromatic hydrocarbons and higher alcohols, which are always present in petrol, paraffin, methylated spirits, diesel fuel etc. They are also present in varying concentrations in products such as fly sprays, some teat dip solutions and are sometimes used as propellants in aerosol cans.

Great care must be taken to ensure these products do not come into contact with plastic components on milking machines.

DRI bv will not accept responsibility for equipment damaged by chemicals.

DRI will not take any responsibility for any damage resulting from frost. The owner/user must take the necessary measurements to prevent the ambient temperature around the equipment from dropping to or below freezing point.

Modification may create risks not covered by the original construction. Do not make any modification which has not been approved by DRI.

Mandatory!

Read the instructions carefully before using the equipment. Contact DRI if there are parts of these instructions that are not understood. Compliance with the instructions ensures a correct and safe use of the equipment. Save the instructions for future reference.

The installation and/or service of the equipment must be carried out by an authorised mechanic.

Warning!

Never use the equipment for any other purposes than the intended use.

The system must only be operated by trained personnel. Make sure that children and unauthorised persons do not come into contact with the system.

Caution!

Airwah Plus is based on the disinfectant solution, water, and air. Caution when handling chemicals is required.

Note!

Failure to observe installation and operating instructions may lead to the warranty being restricted.

Risk of electric shock

Always disconnect the main power supply, and if present lock the main switch in off position, before performing any installation, inspection, adjustment, maintenance, or service on the equipment. Wait for all moving parts to stop and any capacitors to discharge.

The electrical installation or any other work on the electrical equipment must be done by an authorised electrician. It must be in compliance with national regulations and the supplied wiring diagrams.

The wires in the mains lead of the power supplies are coloured in accordance with the following code:

Blue to N (neutral)
Brown to L (live)
Yellow/Green to E (ground)

Do not spray or flush water on electrical components even when they are switched off or disconnected. Water on electrical components can cause an electric shock, and will destroy the equipment.

Always isolate all electronic equipment totally from the mains supply if large currents are applied to the milking machine.

If a stand-by generator is used to supply mains voltage, first disconnect all electronic equipment totally from the mains. Start the generator and check the stability of the generated current before connecting the electronic equipment.

AirWash-Plus - The perfect circle for conventional milking!

AirWash-Plus is the most flexible and affordable automated dip and rinse system for your parlor available on the market in this area.

Automatic teat dipping, milking cluster disinfection and rinsing with clean tap water is safe, quick and easy! All this is possible without having to purchase special milk liners, teat cups or milking cluster.

The fact is that automation reduces the likelihood of human error and reducing labor and inefficiencies provides more consistency in the milking process.

The combination of these advantages, all evident in the revolutionary AirWash-Plus System, automatic dipping and backflushing system can improve the milk quality in your herd and have a positive influence, which is the foundation of your dairy farm.

The revolutionary AirWash-Plus System can increase the health of the herd.

Leave nothing to chance!

Thanks to the AirWash-Plus System, you can:

- Gain efficiency by reducing workload or achieving faster parlor throughput
- Reduce the risk of one sick cow infecting the entire herd and thus minimize the risk of mastitis.
- Minimize stress and unrest by simplifying and standardizing your work process.

Reliable milking, Dip and Backflushing with AirWash-Plus

Discover the ultimate Dip and disinfection technology ...
The AirWash-Plus System automates two important, time-consuming work steps at the end of the milking process:

- 1 Reliable and accurate dipping of the teats after milking,
- 2 Effective disinfection of the entire claw after each individual milking process ... and thus improve udder health with great care:

Automatic teat care with a backflush function eliminate over 98% of the organisms that can infect the next cow with potential germs: milking, dipping and sanitizing in a single pass!

This means significantly less downtime and treatment costs.



Automatic dipping - accurately and safely

Dip application in the best way: The AirWash-Plus System covers the teats at the best time. Dipping directly into the teat cup is accurate. AirWash-Plus automatically always ensures outstanding consistent dipping quality and thus full protection around the milk-canal and teats!

Optimal time, optimal amount, optimal protection

The teat is dipped at the best time with the optimal amount of dip. The teat is treated while it is limp and stretched by the vacuum. This optimizes the dip application. It can penetrate deep into the skin to ensure complete protection of each teat before the cluster is removed.

Automated dipping and rinsing results in efficiency gains

You can rely on the consistent of the dip procedure. Automatic dipping replaces the manual constant repetitive movements during dipping and / or spraying at the end of the milking process. This improves the working routine, provides room for proper udder preparation and makes the milking parlor more efficient that results in higher throughput.

Saving dip consumption, low operating costs

The dip applied is always fresh and uncontaminated. The dip amount is adjustable and can be precisely controlled.

This unique working method ensures minimal dip consumption and consistent application so that the AirWash-Plus System always works economically.



How does it work?

The teat cup liner dip process, how does it work?

1. The teat is dipped by spraying the dip spray from the short milk hose onto the bottom of the teat,
2. Even distribution due to the patented Airwash-Plus injector
3. The milk duct is shielded before it is exposed to the environment.



Reduction of infectious organisms thanks to BackFlush

Automatic backflushing and disinfection of the milking cluster: the AirWash-Plus System does not give pathogens a chance.

An intensive rinsing process is completed before the next milking session, removing any residual dip in the cluster, disinfecting and rinsing with clean water while waiting for the next cow.

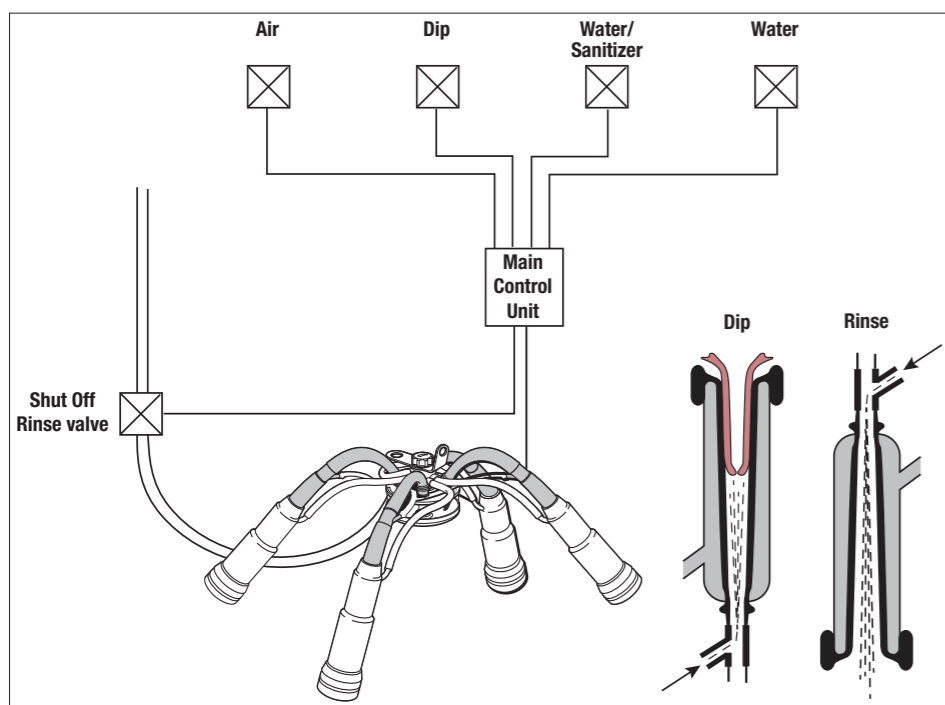

schematic arrangement

How does it work?

A clean and healthy place

The entire milking cluster is effectively cleaned for the next cow. This kills infectious organisms that reside in the milk liner, bowl and long milk hose of the milking unit to reduce the chance of mastitis spreading through milking equipment.

Alternating water cycles are blown out with powerful blasts of air, creating turbulence in the cluster and reducing the amount of water required to effectively flush the unit.

The key to milk quality

Because it is possible to rinse the whole thing with clean water and blow dry the milk liners by means of a long blast of air, the milk and the disinfecting media are carefully separated from each other.

Operational safety is constantly under control, the AirWash-Plus Control Unit (main control) monitors system pressures and chemical levels and alerts the user if there is a problem that could be affecting proper operation. You always have your finger on the pulse to ensure consistent system performance.

Is the AirWash-Plus System suitable for your farm? Sure!

Whether rotary parlor, side by side, open tandem, herringbone and swing-over parlor:

Thanks to AirWash-Plus, the operator can concentrate on other tasks that can improve milking and udder health.

The AirWash-Plus System with its revolutionary Dip and BackFlush technology is the right choice for any parlor and is the start of profitable milk production.



How does it work?

The AirWash-Plus System has 3 versions

The uniqueness of AirWash-Plus is not only that the dairy farmer can continue to use the “existing” milk liner and cluster, but because countries and / or authorities apply different regulations, we can, as it were, “custom-made” the AirWash-Plus System. Available in 3 different versions:

1. AWP-Regular
2. AWP-Pro
3. AWP Gold

AWP-Regular

The teat is sprayed by a patented injector located in the short milk hose. The cluster is removed and is in the normal park position.

Disinfection on the inside of the milk liners can now take place by means of the so-called backflush function.

Alternating cycles with a mix of water / disinfectant and air rinse the dip agent out of the milk liner and also has a disinfecting effect! These alternating cycles can be easily adapted to suit everyone’s needs.

AWP-Pro

The treatment of the teats is the same as in the AWP-Regular variant described above. With AWP-Pro, the long milk hose is closed as soon as the ACR is activated, rinsing and disinfection now takes place not only on the inside of the milk liner, but also through the long milk hose, so that the entire milking cluster is disinfected and rinsed clean on the inside.

The milking cluster is in the lowest position during this phase of the flushing, this is possible because the decrease signal is interrupted, causing the milking cluster to lower by gravity.

When the rinsing process is complete, the detachment is reactivated and the long milk hose unblocked so that the milking cluster returns to the normal park position. All of this is controlled by the individual AWP-Pro controller.

AWP-Gold

This variant of the dip and rinsing process is identical to the AWP-Pro variant described above, but in order to exclude any form of residue, the whole is rinsed with clean tap water at the end, reducing the risk of residues to a minimum is limited.

AirWash-Plus System is variable and flexible

Not only the amount of dip, water and air can be perfectly adjusted to the wishes of the customer, but it is also possible to “upgrade” the system at a later stage from a **Regular** to a **Pro** or **Gold** version.

Schematic setup Main Components

Set-up Airwash Plus

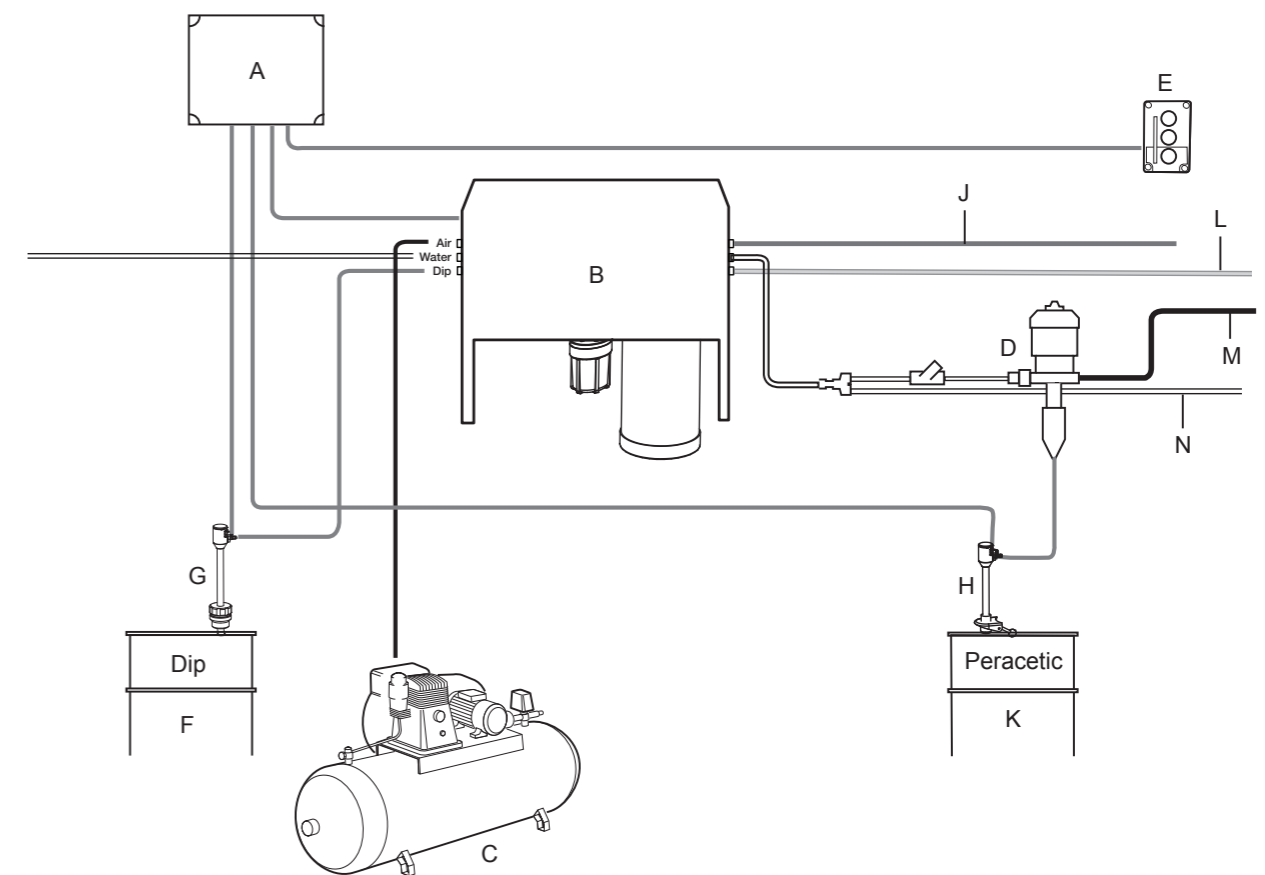

- A. Transformer
- B. AWP Pump & Filter Cabinet
- C. Air compressor
- D. Dosatron
- E. Low level indicator
- F. Dip drum
- G. Low Level Indicator probe

- H. Low Level Indicator probe
- J. Dip line (red)
- K. Disinfectant drum
- L. Air line (blue)
- M. Disinfectant line (black)
- N. Clear water line (natural)

Schematic setup Main Components

Ring circuit

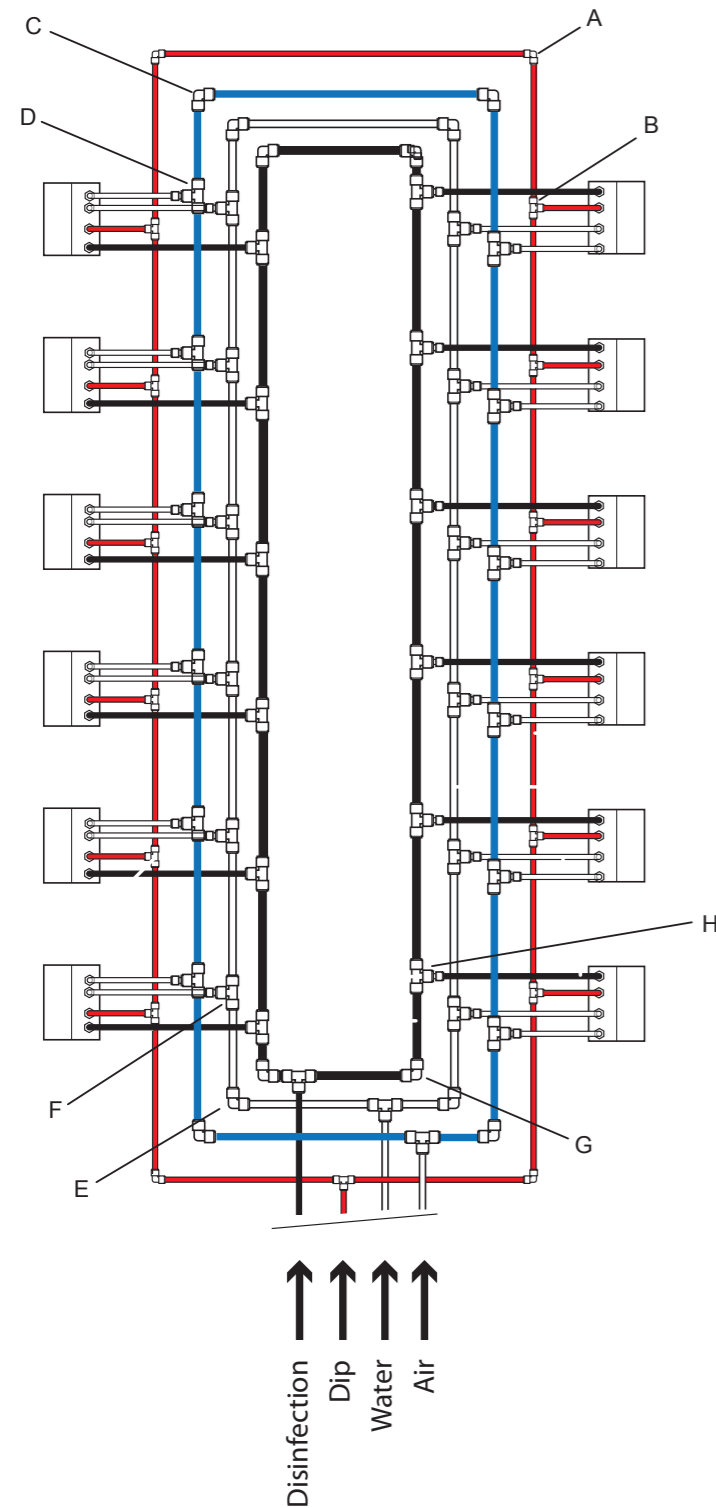

- 8 mm Dip ring (red DRI-885)
- 12 mm Air ring (blue DRI-964)
- 12 mm Water ring (transparent DRI-965)
- 12 mm Disinfection ring (black DRI-966)

- A. Angle Dip 8 mm (DRI-891)
- B. T-Piece Dip 8 mm (DRI-890)
- C. Angle Air 12 mm (DRI-899)
- D. T-piece Air 12>8 mm (DRI-898)
- E. Angle Water 12 mm (DRI-969)
- F. T-piece Water 12>8 mm (DRI-968)
- G. Angle Disinfection 12 mm (DRI-969)
- H. T-piece Disinfection 12>8 mm (DRI-968)

Note:
From the ring circuit to the control box a T-piece 12 > 8 mm is used, From there a small piece 8 mm tubing is needed.

- 8 mm Air supply line (DRI-886)
- 8 mm Water supply line (DRI-883)
- 8 mm Disinfection supply line (DRI-884)

Schematic setup Main Components

Set-up dry area

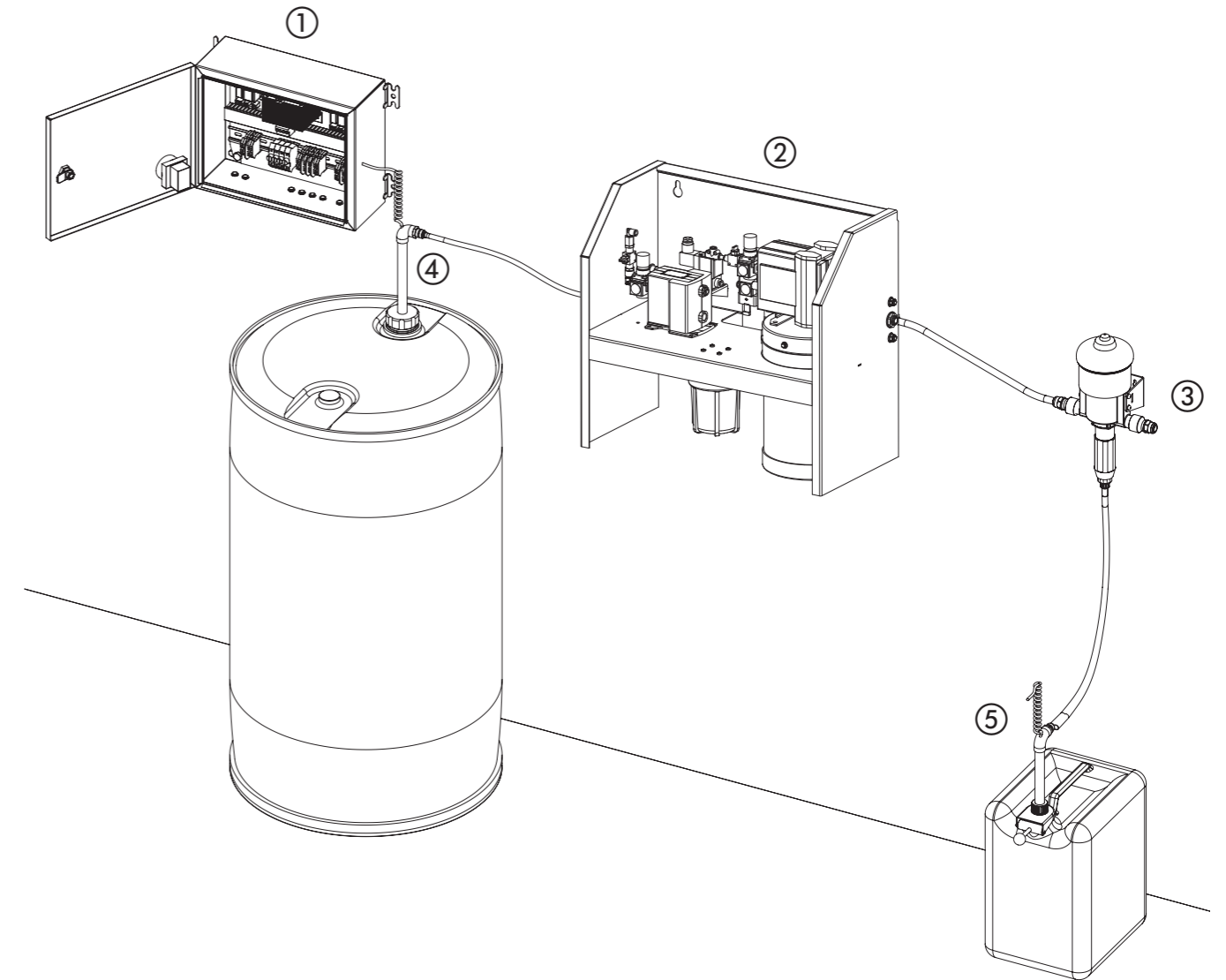

1. AWP Main Control Unit
2. AWP Pump & Filter Cabinet
3. AWP Dosing Unit
4. AWP Probe / Sensor 200 L. (dip - long)
5. AWP Probe / Sensor 30 L. (sanitizer - short)

Transformer	
Single primary voltage	230 V, electrical plug
Power rating	250 VA / 500 VA
Secondary voltage	0-24-27-30 V
Frequency	50/60 Hz
IP rating	IP-55
Insulation class	B (130°C)
Low level indicator controller	
Single primary voltage	230 VAC, electrical plug
Secondary voltage	0-24 VAC
Frequency	50/60 Hz
IP rating	IP-42
Low level indicator	
Secondary voltage	0-24 VAC
Frequency	50/60 Hz
IP rating	IP-42
Low level indicator probe	
Maximum operating temperature	40°C
Min. Operating temperature	5°C
Individual control box	
Power rating	20 VA
Single primary voltage	24 V/50-60 Hz
Frequency	50/60 Hz
IP rating	IP-42

Dosatron	
Operating pressure	0.3-6 bar
Water flow range	10 L/H - 2.5 m3/h
Injection range	0.07 - 10%
Maximum operating water temperature	40°C
Minimum operating water temperature	5°C
Air filter regulator	
Operating pressure	0-12 bar
Flow rate	850 - NI/min
Maximum operating temperature	50°C
Minimum operating temperature	5°C
Water filter	
ISO 8573-1 class 1.7.2.	
Solid contaminants: 0.01 µm	
Oil content: < 0.001 p.p.m. at 21°C	

Water and disinfectant quality and consumption

The approximate water consumption is 700 ml / cluster (in disinfectant cycle) and 100 ml / cluster in the last cycle for the Airwash Plus Gold.

To ensure sufficient cleaning, the water should be of drinking quality and a minimum of 500 ml of water per cluster per flushing is required.

Recommended disinfectant is Peradis. Dosage recommendations from the label on the disinfectant should be followed and the right dilution checked with peracetic acid test strips provided in the package.

Note:

By larger parlors we recommend to use one or more transformers.

We recommend a maximum of 10 control boxes per transformer of 250 VA.

Siting of cable ducts, water and air circuit and air filter

Positioning of cable ducts

In the cable ducts on the upper side, drill three (Regular & Pro) or four (Gold) 15 mm holes in the cable ducts per milking point. This is for the water and air supply to the AirWash Plus control boxes.

In some cases the holes will be at the bottom of the cable duct.

The precise siting of the drill holes is determined when it is clear where the control boxes can be placed.

The electric supply to the control boxes is provided from the bottom side of the cable duct.

The 2 holes for the electric cables are drilled from below. For the last two sockets, only 1 hole is required.

NOTE:

 **DUTCH RESEARCH & INNOVATIONS** does not supply the air compressor necessary for the AirWash Plus system to work. The minimum requirements for the capacity of the air compressor are:
500 litres per minute / 300 litres tank.

Water, air and dip ring circuit

The ring circuit from milk point to pump is connected using PA hose. The length of the 12 mm supply line between the milking points depends on the size of the parlour. Only the red dip supply line is 8 mm.

See page 12 for the schematic drawing.



DO NOT SAW THE PE/PA HOSE!

It is extremely difficult to remove the resulting shavings from the line system and these may lead to blockages and malfunctioning in operation. **A special pipe cutter must be used to cut the pipe.**

It is important that the pipe sections for the push fit joints in particular are cut precisely at right angles because otherwise there may be leaks.

Important: The line should always be laid in a circuit.

Push-fit joints

1. Cut the pipe square. It is essential that the outside diameter is free of score marks and burrs and sharp edges are removed before inserting into fitting.
2. Push the pipe into the fitting, to the pipe stop. The collet (gripper) has stainless steel teeth which hold the tube firmly in position whilst the O-ring provides a permanent leak proof seal.
3. Pull on the pipe to check if it is secure. It is good practice to test the entire system before first use.

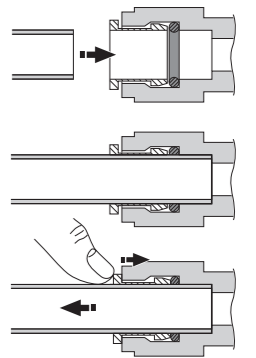

NOTE

Take great care with sealing when installing the unit as the smallest leakages lead to malfunctioning in view of the relatively high pressures. All push-fit joints should be carefully and properly made.

NOTE

The PE/PA line should be laid as far as possible in the cable duct because this also provides good protection of the line.

After the installation of the ring circuit has been completed the T-pieces (12 mm with 8 mm reducing pieces) are fitted in the correct position after the line has been separated at the appropriate points (special cutter).

Water supply to the AWP Pump & Filter Cabinet (DRI-3902 / DRI-3904)

After the water reservoir has been fitted please check the following points:

1. Is the float present/correctly fitted
2. Is the float functioning
3. Is the hose-connection correctly fitted

NOTE

The water supply of the water reservoir must be a separate line which can be shut off. For good results with AirWash Plus, drinking water quality is a prerequisite.

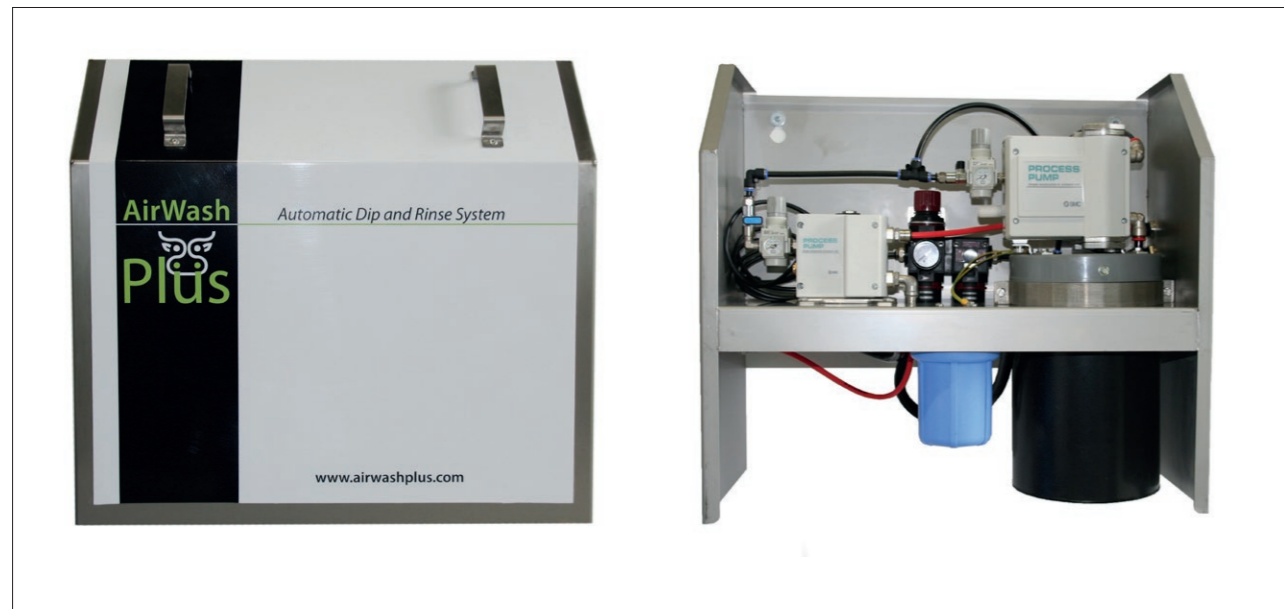

Make sure that AirWash-Plus control components are placed in a dry and frost-free location and that the AirWash-Plus Pump & Filter Cabinet is connected to a drinking water quality network. This is to prevent components from stagnating due to too high lime and / or iron-containing water, so that the correct operation of the AirWash-Plus System can no longer be guaranteed.

Since the media of the AirWash-Plus system are pumped by means of air pressure, it is of the utmost importance that an air compressor is installed that is technically in good condition and has the correct capacity.

The air compressor is normally not supplied with the AirWash-Plus system.

DRI bv therefore advises to use an air compressor with the following specifications:

500 L/min with a storage tank of 300 liters with automatic water drainage and air dryer (preferred).

Presetting of the air compressor for the best result is between 8 and 10 Bar.

We recommend that you carefully follow the manufacturers service instructions to avoid problems with the air supply.

For big parlors we advise a buffer airtank (12Liter, DRI-850) close to the control boxes to have a sufficient amount of air.

This stainless steel Pump & Filter Cabinet features a detachable lid for easy access to all components and is supplied ready for operation so all components are operational and ready to go.

The whole can be attached by means of 2 wall anchors through two mounting holes at the top of the Pump & Filter Cabinet.

Input and **Output** connections are indicated on the sides of the Pump & Filter Cabinet by means of a sticker with imprint.

Designation Left Input side:

----- **24 VAC Input:** This 24VAC power supply comes directly from the AirWash-Plus Main Control Unit (DRI-3903) see page 23.

This power supply is to open the central air valve when the milking process is about to begin and the air pressure and fluids can be pressurized.

When the power fails, the entire AirWash-Plus system is pressureless.

----- **Air Input:** This 12 mm push-in connection is powered by the local air compressor. This must have a minimum capacity of 500 L/min. with a storage tank of 300 liters.

Make sure that the air compressor is in good condition and is regularly serviced as prescribed by the manufacturer.

Since AirWash-Plus pumps several mediums, color-coded pressure hoses are used! Use Blue colored Air hose which is included in the AirWash-Plus kit (DRI-965).

----- **Water Input:** This connection is fed by water of drinking water quality and is prepared with a 13 mm hose tail.

----- **Dip Input:** This 8 mm Push-in connection is fed by a Dip fluid recommended by DRI, for example DeLaval Proactive test dip.

Since AirWash-Plus pumps several mediums, color-coded pressure hoses are used! Use Red colored Dip hose which is included in the AirWash-Plus kit. (DRI-885)

Designation Right Output side:

----- **Dip Output:** This 8 mm Push-in connection is the outlet of the Dip liquid which is supplied by a Dip liquid recommended by DRI or by a DRI, for example. This Red colored pressure hose transports the Dip liquid to the milking parlor.

Since AirWash-Plus pumps several mediums, color-coded pressure hoses are used! Use Red colored Dip hose which is included in the AirWash-Plus kit. (DRI-885)

• **Dip Output Regulator should be 0,4 MPa.**

----- **Water Output:** This 12 mm Push-in connection is the output of the Water supply. Use the Black colored 12mm pressure hose, which transports the rinsing water to the milking parlor.

Since AirWash-Plus pumps several mediums, color-coded pressure hoses are used! Use Black colored Water hose which is included in the AirWash-Plus kit. (DRI-966)

• **Water Output Regulator should be min. 0,4 MPa and max. 0,5 MPa.**

----- **Air Output:** This 12 mm push-in connection is the outlet of the air supply to the milking parlor

Since AirWash-Plus pumps several mediums, color-coded pressure hoses are used! Use Blue colored Air hose which is included in the AirWash-Plus kit. (DRI-965)

• **Air Output Regulator should be 0,8 MPa.**

AWP Pump & Filter Cabinet (DRI-3902)

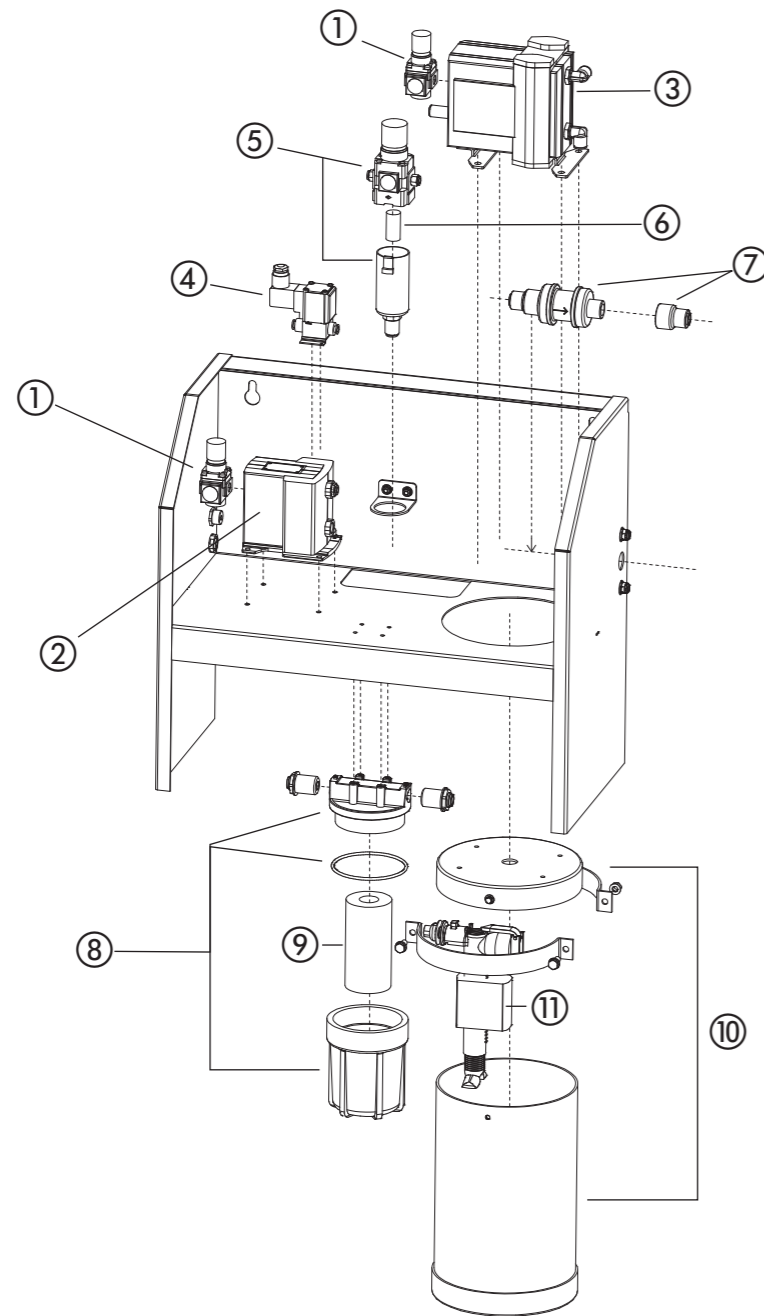

Description

Description	DRI no.
AWP Pump & Filter Cabinet 2x 250 VA	DRI-3902
1 Air Regulator (SMC)	DRI-987
2 Dip Pump (SMC) INOX 8mm	DRI-986
3 Water Pump (SMC) INOX 12mm	DRI-984
4 Air Solenoid valve main supply cabinet (SMC)	DRI-357
5 Air filter & Regulator (SMC) Cabinet	DRI-1801
6 Air filter cartridge (exchange SMC)	DRI-1802
7 Water One Way valve	DRI-1023
8 Filter housing Water + cartridge	DRI-926
9 Water filter cartridge	DRI-352
10 Water container	DRI-907
11 Float-valve	DRI-4023

AWP Dosing Unit (DRI-1020)

The Dosing Unit does not have to be connected to the power supply. Once connected to the Airwash Plus water mains, the water pressure is the only driving force for the engine piston. This drives a dosing piston that draws the concentrate into the set percentage and then mixes it with the driving water. The solution thus obtained is then distributed via tubing. The amount of concentrate injected is at all times proportional to the amount of water that passes through the dosing device, even if there are any fluctuations in the water pressure and flow in the network. This model is suitable for doses of 0.2 percent up to and including 2 percent.

The dosing device is positioned at about 1 meter distance from the 12mm Water pump (DRI-3902) output. Dosing unit can be mounted on the wall with the supplied wall bracket. There are also 2 pieces of 3/4 "x 12 mm push-in couplings supplied to easily place the dosing station between the 12 mm water pipe, mount it hand-tight.

Select the correct setting depending on the concentration of peracetic acid. This can be measured with the Peracetic Acid Test Strips (DRI-1022).

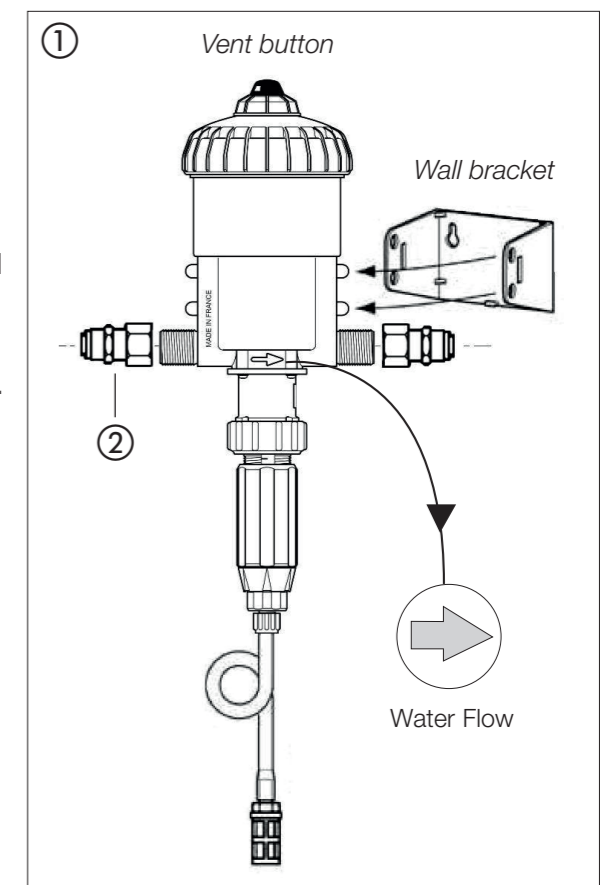

Note

The arrow indicated on the front of the dosing station indicates the flow direction!

Venting dosing unit

When connecting the dosing unit, the dosing unit must be vented before its put into operation. Venting is done as follows:

1. Partially open the water supply from water pump by turn the shutoff valve to open, clockwise.
2. Then press the vent button, located on top of the dosing unit
3. Release the button when a constant flow of water flows past the vent button
4. Open the water supply from water pump completely, the dosing unit is self-priming
5. Let the water pump work until the injection liquid has been sucked into the dosing tube
6. The pump is running when you hear a clicking noise.

AWP Dosing Unit (DRI-1020)

Setting dosage

When you want to set the dosage of the pump, it is important that there is no water pressure on the dosing unit.

In addition, it is important not to use tools. You can set the dosage as follows:

1. shut off water pump supply line.
2. press and hold the vent button until no more water pressure is present inside water line.
3. then loosen the conical nut / locking ring.
4. turn the metering nut counter clockwise or clockwise so that the adjustment seam is in the eye of the adjusting ring until corresponding to the desired dosage.
5. finally, retighten conical nut / locking ring again.

DRI-1022

The Peracetic Acid test strips allow quick, easy and reliable measurement.

Gradation: 0 - 500 - 1000 - 1500 - 2000 mg/L

These high-tech strips are ideal for a quick semi-quantitative determination.

Made from environmentally friendly plastics, the test strips are easy and safe to throw away in the rubbish bin after use.

For the best results, package should be closed as soon as possible after removing a test strip. The product can be used until the expiry date. Take this test at the head of the milk lining during the back-flush function of the Airwash Plus system.

Compare the colour of the stick with the colour of the example to arrive at a correct dosage.



Note:

The colour must not be above 500 mg/L.

Description	DRI no.
1 Dosing Unit	DRI-1020
2 Reducer socket 3/4x12mm	DRI-992
3 Peracetic Acid Test strips	DRI-1022
Repairkit for Dosing unit	DRI-1025

AWP Main Control Unit (DRI-3903 / DRI-3904)

The siting of the transformer is important. It is best sited reasonably close to the other AirWash Plus parts, but must be clear of the Proactive chemical tub. It must not be placed over open water as condensation can cause damage.

The AWP "Main Control Unit" ensures that the local network voltage of 230VAC is converted into 24VAC and provides the control current for the switch boxes DRI-3908 / DRI-3909 / DRI-3915 which are placed in the milking pit. The MCU also ensures that both Level Indicators are controlled by means of a signaling box.

This 24VAC is the power supply with which the AWP system is controlled.

The AWP "Main Control Unit" consists of the following components:

1. Transformer box from 230VAC - 24VAC
2. Probe / Sensor 200 Liter.
3. Probe / Sensor 30 liters.
4. Signaling box

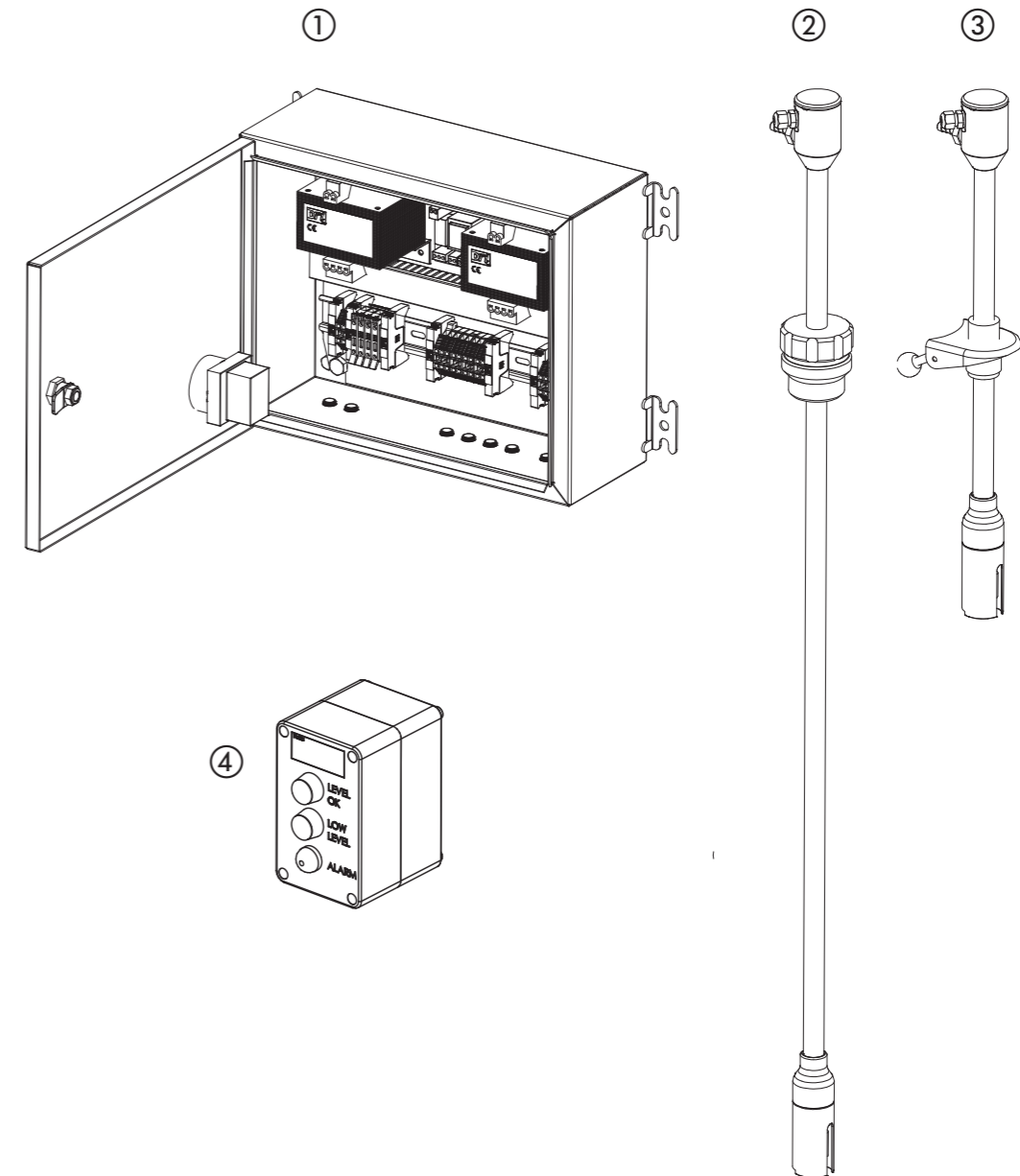

AWP Main Control Unit (DRI-3903 / DRI-3904)

Transformer cabinet ①

DRI-3903 contains 2 transformers of 250 VA, suitable for parlors up to 20 milking points.

DRI-3904 contains 2 transformers from 20 milking points.

Make sure that the AirWash-Plus control components are placed in a dry and frost-free location.

The Main Control Unit can be connected to the local mains of 230VAC which is fused with 16Amp. Have a local electrician install a wall outlet near the Main Control Unit so that the MCU can be turned on.

The transformer cabinet is a stainless steel cabinet with a hinged door with 4x supplied mounting brackets. The connection diagram of the Main Control Unit is located on the inside of the hinged door. The whole is secured with slow glass fuses 5x20 mm.

DRI-3903: 6.3 A Fuse with articlenumber DRI-661 / 8.0 A Fuse with articlenumber DRI-662

DRI-3904: 4.0 A Fuse with articlenumber DRI-663 / 20 A Fuse with articlenumber DRI-664

Low Level Indicator 200 Liter ②

The Main Control Unit comes with a 200 Liter suction probe to signal the liquid level so that timely action can be taken to top up liquid or change a vessel.

1 x Low Level Indicator (long) for Dip fluid which is suitable for 200/1000 Liter barrels with item number DRI-1106.

The hose plug-on nipple which is attached to the head of the suction lance is suitable for a hose with an inner diameter of 6mm. A red hose is used for this and is supplied with the AWP system under number DRI-885.

Low Level Indicator 30 Liter ③

The Main Control Unit comes with a 30 liter suction probe to signal the liquid level so that timely action can be taken to top up liquid or change a container.

1 x Low Level Indicator (short) for disinfectant liquid (Peracetic Acid) which is suitable for 30 liter drums with article number DRI-1107

The hose plug-on nipple which is attached to the head of the suction lance is suitable for a hose with an inner diameter of 6mm. This hose is supplied with the AWP Dosing unit DRI-1020.

Important!

The two level / alarm detectors, which differ in length, are designed in such a way that they are not interchangeable to prevent fluid mix-ups.

AWP Main Control Unit (DRI-3903 / DRI-3904)

Signaling box ④

The Main Control Unit comes with a level / alarm detector.

This signaling box is mounted in or around the milking parlor in order to warn the milker when one or more liquids are about to run out and to refill or change the liquid vessels in time.

- Illumination of the green lamp provides a visual indication that the liquid level of both liquids is still sufficient.
- Illumination of the red lamp is a visual indication that the liquid level of one or both liquids is no longer sufficient, a buzzer will also sound at the same time to also attract audio attention.

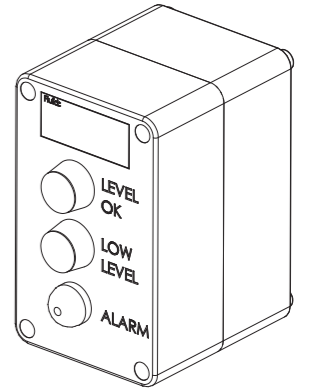

Connection diagram Transformer box DRI-3904

The connection diagram shown below can be found on the inside door of the transformer box.

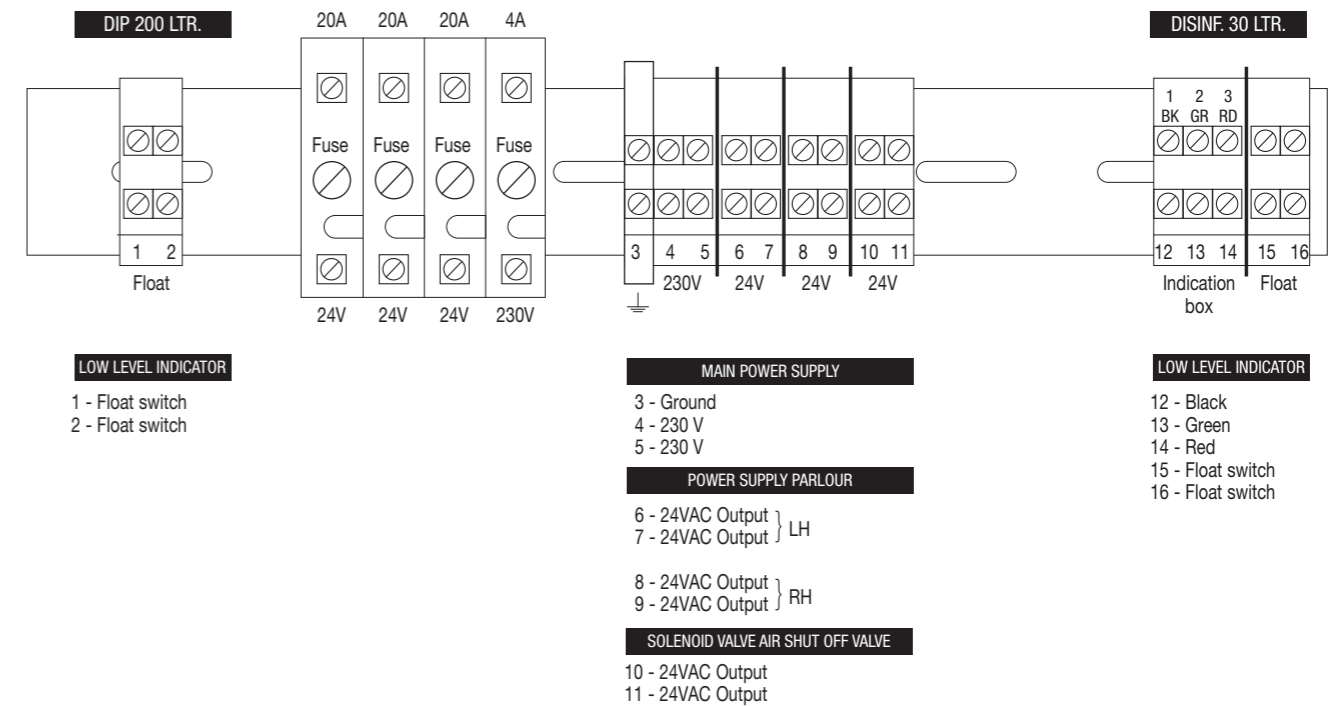

- 1 - 2 Connection contact for the Low Level Indicator 200/1000 Liter drum of Dip liquid.
- 3 Grounding
- 4 - 5 Input 230VAC of the local mains. Power supply for AirWash-Plus System
- 6 - 7 24VAC output which provides the power for the first Control box in the milking parlor (If applicable) For the left side of the parlor.
- 8 - 9 Output 24VAC which provides the power for the first Control box in the milking parlor (If applicable). For the right side of a the parlor.
- 10-11 24VAC output for Main air valve of the AirWash-Plus Pump and filter Cabinet (DRI-3902)
- 12-13-14 Output 24AV for the level / alarm detector, which should be placed in the milking parlor.
- 15 - 16 Connection contact for the Low Level Indicator 30 liter drum of disinfection liquid (Peracetic Acid)

AWP Regular (DRI-3908)

Make sure that AirWash-Plus main components are placed in a dry and frost-free location.
The uniqueness of AirWash-Plus is not only that the farmer can continue to use his own milk liners and cluster, but also that authorities apply different requirements and / or regulations, so that the AirWash-Plus System can be offered “custom-made”, as it were. three different versions are: 1 AWP-Regular, 2 AWP-Pro, 3 AWP-Gold.

AWP-Regular With the AWP Regular, the teats are treated when the teat is still in the milk liner after milking, by a patented injector that is located in the short milk hose.

When the detachment is activated, the cluster is removed and is in the normal park position.

Disinfection on the inside of the milk liners can now take place by means of the so-called backflush function.

An alternating cycle of water and air has a disinfecting effect and rinses the milk liner on the inside of dip agent. These alternating cycles can be easily adapted by changing the parameter settings to suit everyone's needs.

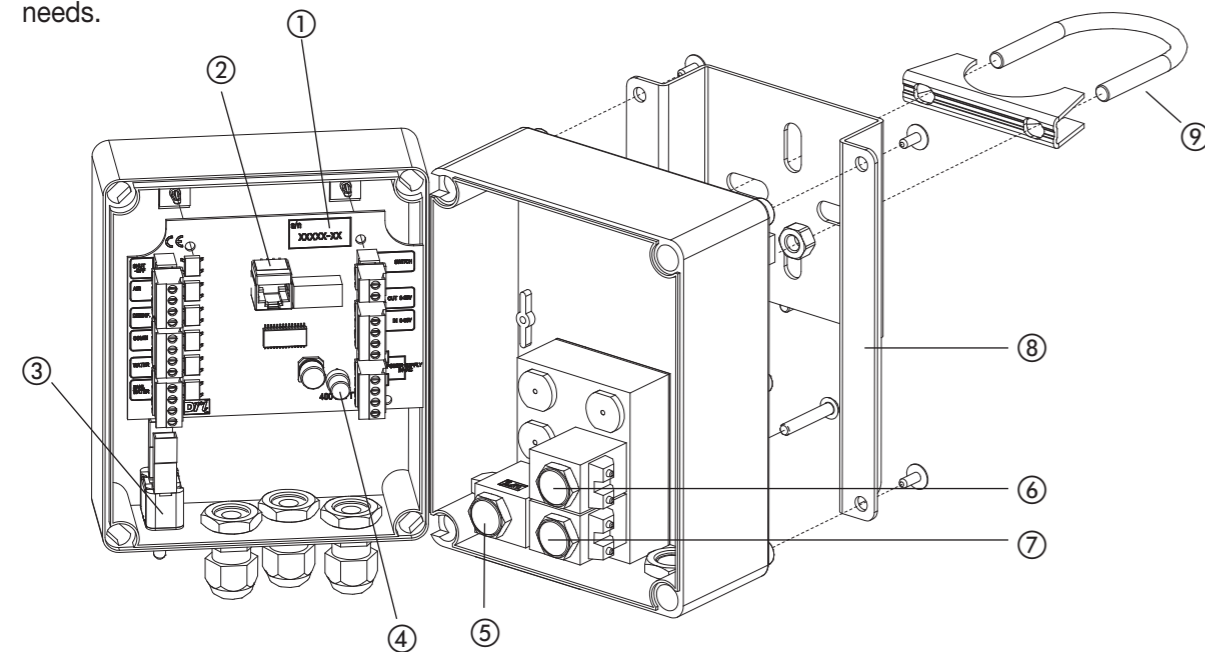

1. Serial number.
2. RJ-45 connector to connect to the AWP Programmer (DRI-8004).
3. ON / OFF Toggle switch.
4. 400 mA Fuse.
5. Rinse Operator.
6. Air Operator.
7. Teat Dip Operator.
8. Mounting bracket.
9. U-saddle

AWP Regular (DRI-3908)

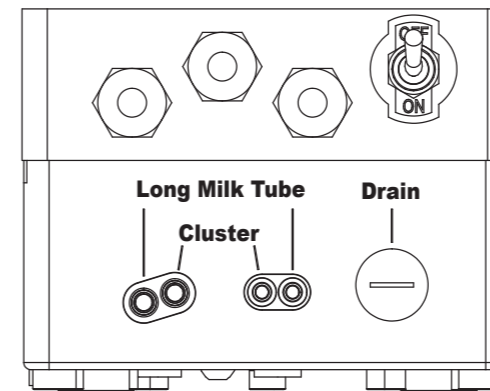

connection at the bottom DRI-3908

At the bottom of the AWP-Regular cabinet are a total of four output ports with different connection diameters.

Toggle switch - At the bottom of the DRI-3908 AWP-Regular control box is a switch, which can be selected in the ON / OFF position.

ON position: during normal use this switch is selected in the ON position, but when a fault occurs, the AWP controller can be switched off per milk position, any delay of the take-off signal is also overruled and the ACR signal will be passed on to the take-off cylinder without delay, making “normal” milking possible.

Long Milk Tube - These connection nipples are not used with an AWP-Regular and are not connected.

Cluster - The AWP end connection DRI-1774 is connected to this connection nipple, which provides the dip and rinsing to the milking claw.

Plug-in nipple OD 6mm (small) medium Dip medium

Plug-in nipple OD 8mm (large) medium Rinse / Air

Drain - This connection nipple is not used with an AWP-Regular and is plugged.

Connection Rear

On the back of the AWP-Regular valve box it is written which medium must be connected where.

Teat dip- This 8 mm push-in connection is for the entry of the Red 8mm Dip Line, DRI-885.

Air- This 8 mm push-in connection is for the entry of the Blue 8mm air line, DRI-886.

Rinse- This 8 mm push-in connection is for the input of the Black 8mm Water / Disinfectant, DRI-884.

Water- The clean water function is not operational with an AWP-Regular and is plugged from the factory with a red plug.



Wiring diagram

The AWP-Regular control box is supplied with mounting bracket and with 2.5 M color coded (Blue – Brown) 2x 1.5mm² control power cable.

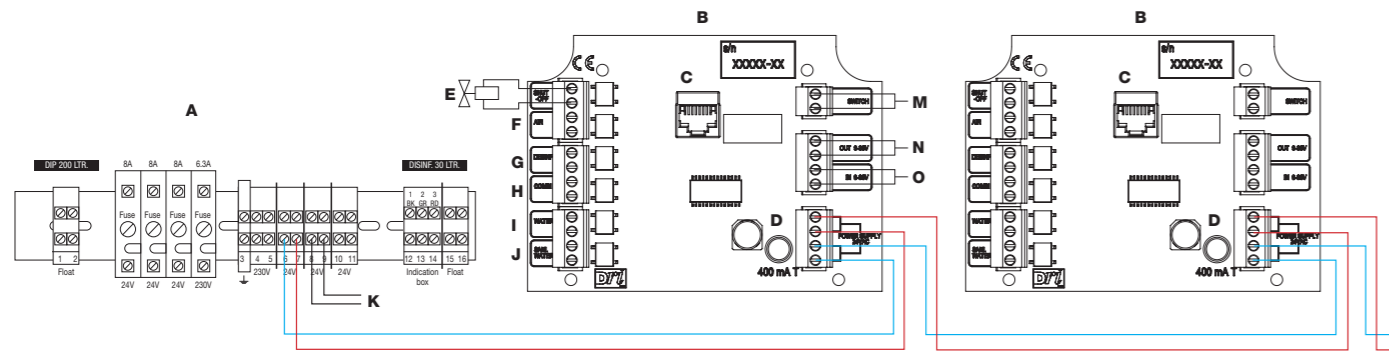

- | | | | |
|---|------------------------------|---|--------------------------|
| A | Main Control Unit (DRI-3903) | I | Water-valve |
| B | Controller per Milking point | J | Sanitizer-valve |
| C | RJ-45 Connector | K | Power connection LH side |
| D | Fuse 400mA | L | To next Controller |
| E | Pinch-valve | M | ON/OFF Toggle Switch |
| F | Air-valve | N | Output ACR |
| G | Dip valve | O | Input ACR |
| H | Combi-valve | | |

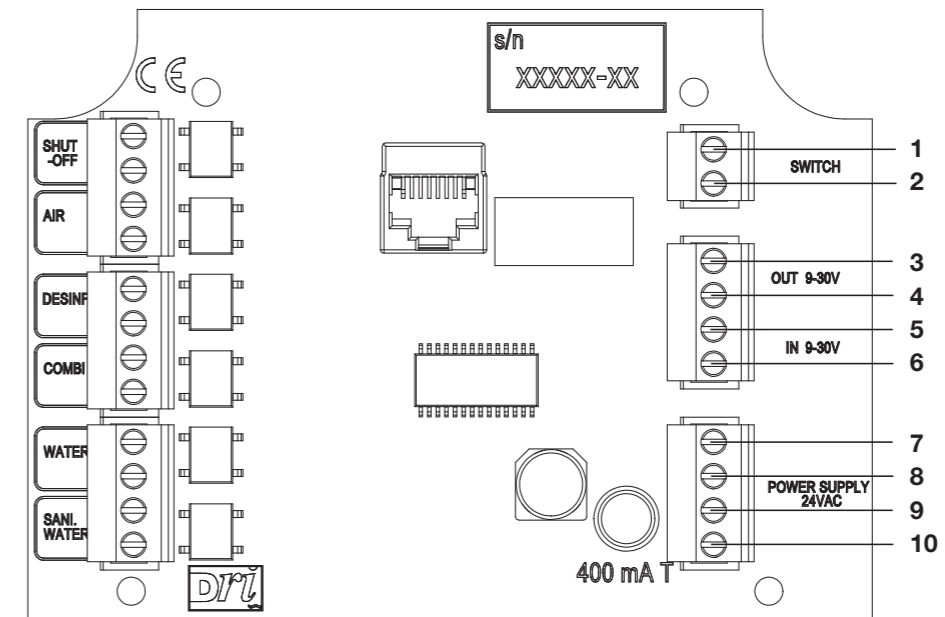

- 1 - 2 Is the connection of the on / off switch which is located at the bottom of the cabinet. With this switch you can turn off the AWP system per milking point when a malfunction occurs. When this switch is selected in the OFF position, the power to the control box is off and the automatic take-off signal (ACR) 5 - 6 is immediately switched to 3 - 4, activating the ACR without delay, resulting in a "normal" milk flow. is possible.
- 3 - 4 Is the delayed or not delayed outgoing signal that goes to the automatic take-off ACR controller. This delay can be set to create the correct dip moment. This signal can vary from 9 VAC / DC to 30 VAC / DC. To achieve this delay, a 4-core control cable must be used.
- 5 - 6 Is the input signal that comes from the and can be passed on with a delay to 3 - 4. This signal can vary from 9 VAC / DC to 30 VAC / DC.
- 7 - 9 Is the connection of the power supply signal of 24VAC which comes from the previous AWP Processing unit (milking point). 7 -Brown and 9 - Blue
- 8 - 10 This connection is equipped with a 2.5 meter control cable that supplies the following AWP Processing Unit (milking point) with power. 8 - Brown and 10 - Blue.

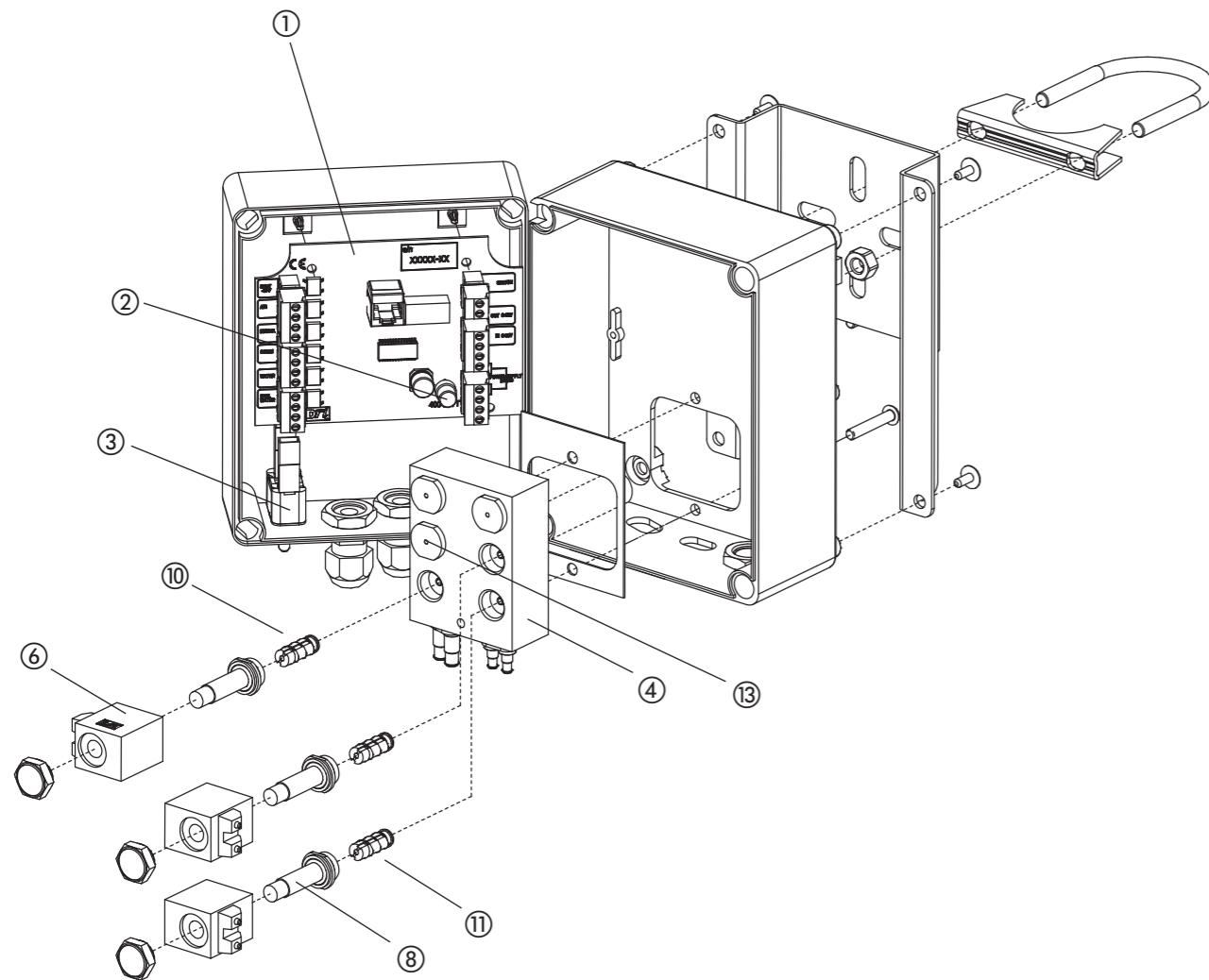

With an AWP-Regular, the combi valve, Pinche valve and the clean water function # 13 are not operational so that on the valve block this operator is plugged as standard with 3x an AWP INOX 14mm Plug (DRI-948).

Description	DRI no.
AWP-Regular Proc. Unit per place	DRI-3908
1 PCB	DRI-611
2 Fuse for PCB 400mA	DRI-660
3 Toggle-switch	DRI-620
4 AWP-Regular 6-way Solenoid-valve with operators	DRI-284
6 Coil for Solenoid-valve	DRI-276
8 Stem M14 + O-ring for 2/2-valve	DRI-260
10 Plunger + Spring (Water/Rins/Combi)	DRI-292
11 Plunger + Spring (Air/Dip)	DRI-291
13 Plug 1/4" INOX for Sol.-valve block	DRI-948

Make sure that AirWash-Plus main components are placed in a dry and frost-free location. The uniqueness of AirWash-Plus is not only that the dairy farmer can continue to use his own milk liners and cluster, but also that different authorities have their own requirements and / or regulations, so that the AirWash-Plus System can be "custom-made" as it were offered, the three different versions are: 1 AWP-Regular, 2 AWP-Pro, 3 AWP-Gold.

AWP-Pro The teat treatment is the same as in the AWP-Regular variant described above. The long milk hose is now closed (by means of a so-called Pinch valve) as soon as the end milk signal is energized, rinsing and disinfection now takes place not only on the inside of the milk liner, but also through the long milk hose, so that the entire cluster is disinfected on the inside and rinsed clean. The milking cluster is in the lowest position during this phase of the flushing, this is made possible by interrupting the decrease signal, causing the milking cluster to lower by gravity. When the rinsing process is complete, the detachment is reactivated and the long milk hose unblocked so that the milking cluster returns to the normal park position. All of this is controlled by the individual AWP-Pro controller.

Note: Since the suspension point depends on the cluster type, a technical adjustment may need to be made.

Pinch valve

This Pinch valve is placed over the long milk hose and is a shut-off valve that closes the long milk hose during the entire dip and rinse process. The position of placing this valve depends on the type and manufacturer of the milking parlor, preferably for the milk meter.

This pneumatic shut-off valve has a 6mm push-in fitting on the top. As a result, the shut-off valve is operated with air pressure.

At the bottom of the DRI-3909 AWP-Pro control box a 6mm Push-in drain coupling is mounted (K), this drain provides the air discharge from the Pinch-valve when it is in the open position.



Injector Long Milk Tube

The injector is placed between the pinch valve and the milk claw, preferably next to the pinch valve. The flow direction of the injector is towards the milk claw. For proper rinsing of the long milk hose and bulb, we recommend using ± 3 meters of hose (DRI-3815) between box and injector.



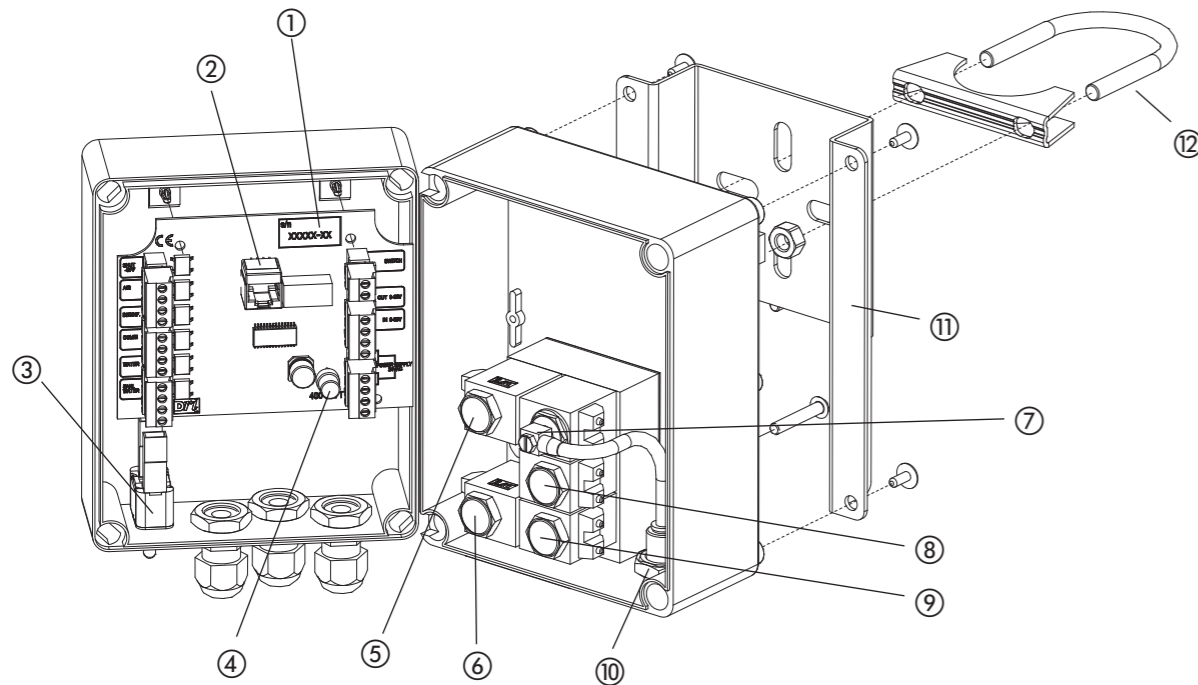

- | | |
|--|---------------------------|
| 1. Serial number | 7. Pinch-valve Operator |
| 2. RJ-45 connector to connect to the AWP Programmer (DRI-8004) | 8. Air Operator |
| 3. 400 mA Fuse | 9. Teat Dip Operator |
| 4. ON / OFF Toggle switch | 10. Air Drain Pinch Valve |
| 5. Combi Operator | 11. Mounting bracket |
| 6. Rinse Operator | 12. U-saddle |

At the bottom of the AWP-Pro cabinet are a total of five output ports with different connection diameters and a toggle switch.

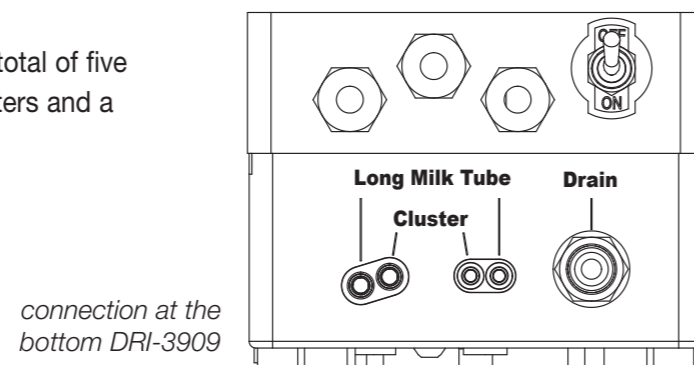

Toggle switch - At the bottom of the DRI-3909 AWP-Pro control box is a switch, which can be selected in the ON / OFF position.

ON position: during normal use, this switch is selected in the ON position, but when a fault occurs, the AWP controller can be switched off per milk position, the delay of the take-off signal is also overruled and the ACR signal will be switched off without delay is passed on to the take-off cylinder, allowing "normal" milking.

Long Milk Tube - This connection nipple controls the Pinch valve and the flushing of the long milk tube. Plug-in nipple OD 6mm (small) air control Pinch-valve. Plug-in nipple OD 8mm (large) medium Rins / Air

Cluster - The AWP end connection DRI-1774 is connected to this connection nipple, which provides the dip and rinsing to the milking claw.

Plug-in nipple OD 6mm (small) medium Dip medium
Plug-in nipple OD 8mm (large) medium Rins / Air

Drain - Air outlet Pinch-valve, if necessary you can extend the outlet with the proper hose.

Connection Rear

On the back of the AWP-Pro valve box it is written which medium must be connected where.

Teat dip - This 8mm push-in connection is for the entry of the Red 8mm Dip Line, DRI-885.

Air - This 8mm push-in connection is for the entry of the Blue 8mm air line, DRI-886.

Rinse - This 8mm push-in connection is for the input of the Black 8mm Water / Disinfectant, DRI-884.

Water - The clean water function is not operational with an AWP-Pro and is plugged from the factory with a red plug.



Wiring diagram

The AWP-Pro control box is supplied with mounting bracket and with 2,5 M color coded (Blue – Brown) 2 x 1.5mm² control power cable.

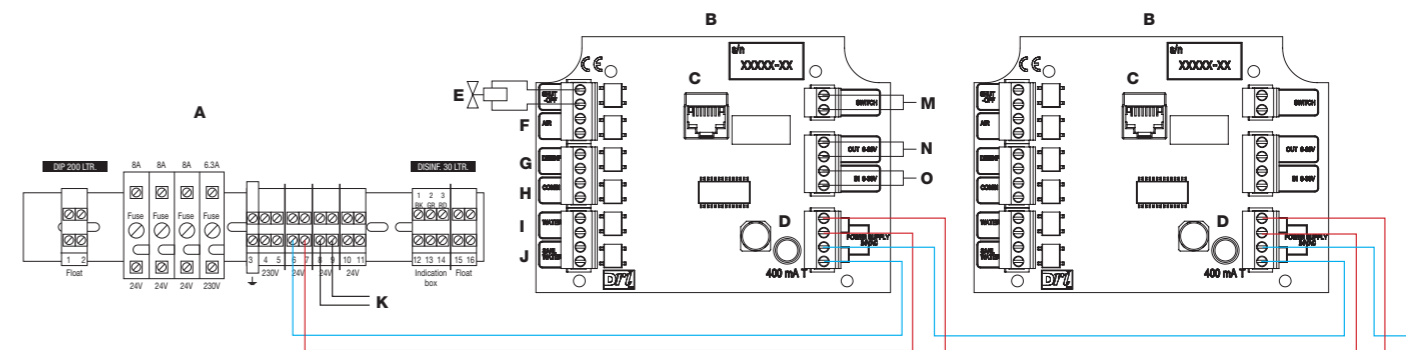

- | | |
|--------------------------------|----------------------------|
| A Main Control Unit (DRI-3903) | I Water-valve |
| B Controller per Milking point | J Sanitizer-valve |
| C RJ-45 Connector | K Power connection LH side |
| D Fuse 400mA | L To next Controller |
| E Pinch-valve | M ON/OFF Toggle Switch |
| F Air-valve | N Output ACR |
| G Dip valve | O Input ACR |
| H Combi-valve | |

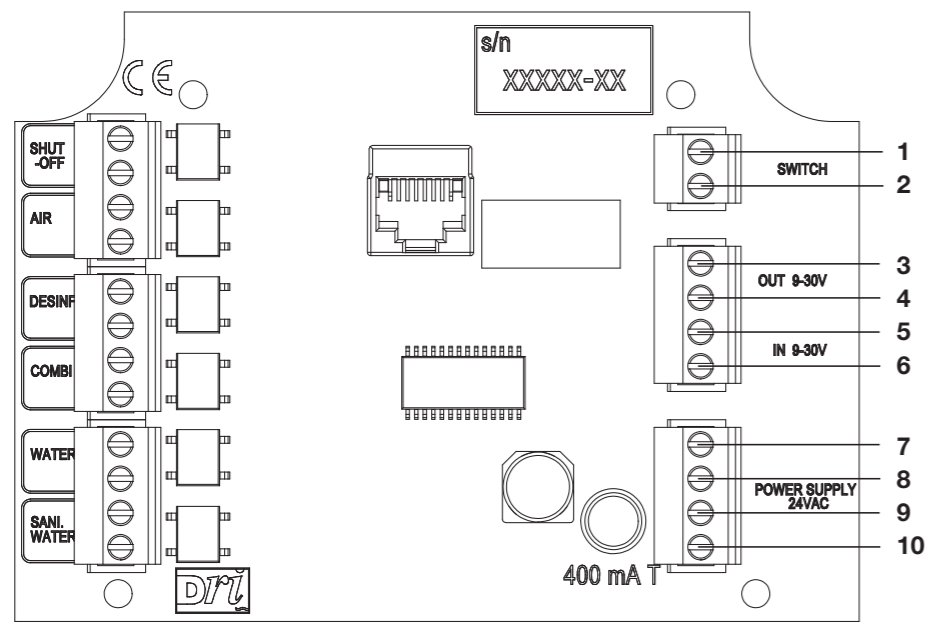

- 1 - 2 Is the connection of the on / off switch which is located at the bottom of the cabinet. With this switch you can turn off the AWP system per milking point when a malfunction occurs. When this switch is selected in the OFF position, the power to the control box is off and the automatic take-off signal (ACR) 5 - 6 is immediately switched to 3 - 4, activating the ACR without delay, resulting in a "normal" milk flow. is possible.
- 3 - 4 Is the delayed or not delayed outgoing signal that goes to the automatic take-off ACR controller. This delay can be set to create the correct dip moment. This signal can vary from 9 VAC / DC to 30 VAC / DC. To achieve this delay, a 4-core control cable must be used.
- 5 - 6 Is the input signal that comes from the ACR and can be passed on with a delay to 3 - 4. This signal can vary from 9 VAC / DC to 30 VAC / DC.
- 7 - 9 Is the connection of the power supply signal of 24VAC which comes from the previous AWP Processing unit (milking point). 7 -Brown and 9 - Blue
- 8 - 10 This connection is equipped with a 1.5 meter control cable that supplies the following AWP Processing Unit (milking point) with power. 8 - Brown and 10 - Blue.

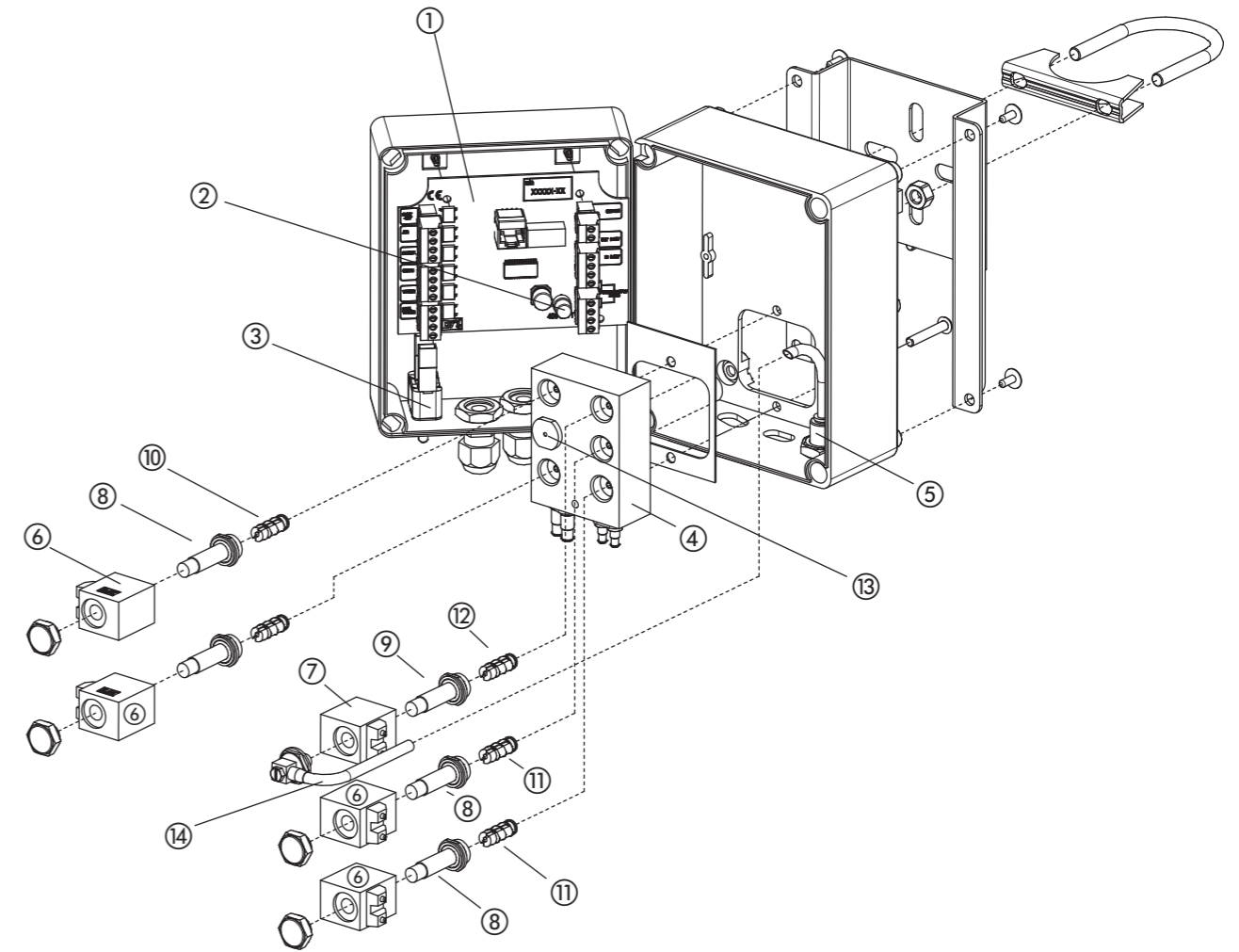

With an AWP-Pro, the clean water function # 13 is not operational so that on the valve block this operator is normally plugged with an AWP INOX 14mm Plug (DRI-948).

Description	DRI no.
AWP-Pro Proc. Unit per place	DRI-3909
1 PCB	DRI-611
2 Fuse for PCB 400mA	DRI-660
3 Toggle-switch	DRI-620
4 AWP-Regular 6-way Solenoid-valve with operators	DRI-284
5 Bulkhead connector (drain) 6mm	DRI-30
6 Coil for Solenoid-valve	DRI-276
7 Coil for Pinch-valve	DRI-277
8 Stem M14 + O-ring for 2/2-valve	DRI-260
9 Stem M14 + O-ring for 3/2-valve	DRI-262
10 Plunger + Spring (Water/Rins/Combi)	DRI-292
11 Plunger + Spring (Air/Dip)	DRI-291
12 Plunger + Spring (Pinch-valve)	DRI-290
13 Plug 1/4" INOX for Sol.-valve block	DRI-948
14 90° x M5 Elbow tube connection	DRI-263

Make sure that AirWash-Plus main components are placed in a dry and frost-free location. The uniqueness of AirWash-Plus is not only that the dairy farmer can continue to use his own milk liners and cluster, but also that different authorities have their own requirements and / or regulations, so that the AirWash-Plus System can be “custom-made”, as it were offered, the three different versions are: 1 AWP-Regular, 2 AWP-Pro, 3 AWP-Gold.

AWP-Gold This variant of the dip and the rinsing process is identical to the AWP-Pro variant described above, but to keep any residue form to a minimum, the whole is rinsed with clean tap water.

Note: Since the suspension point depends on the cluster type, a technical adjustment may need to be made.

Pinch valve

This Pinch valve is placed over the long milk hose and is a shut-off valve that closes the long milk hose during the entire dip and rinse process. The position of placing this valve depends on the type and manufacturer of the milking parlor, preferably for the milk meter.

This pneumatic shut-off valve has a 6mm push-in fitting on the top. As a result, the shut-off valve is operated with air pressure.

At the bottom of the DRI-3915 AWP-Gold control box a 6mm Push-in drain coupling is mounted (K), this drain provides the air discharge from the Pinch-valve when it is in the open position.



Injector Long Milk Tube

The injector is placed between the pinch valve and the milk claw, preferably next to the pinch valve. The flow direction of the injector is towards the milk claw. For proper rinsing of the long milk hose and bulb, we recommend using ± 3 meters of hose (DRI-3815) between box and injector.

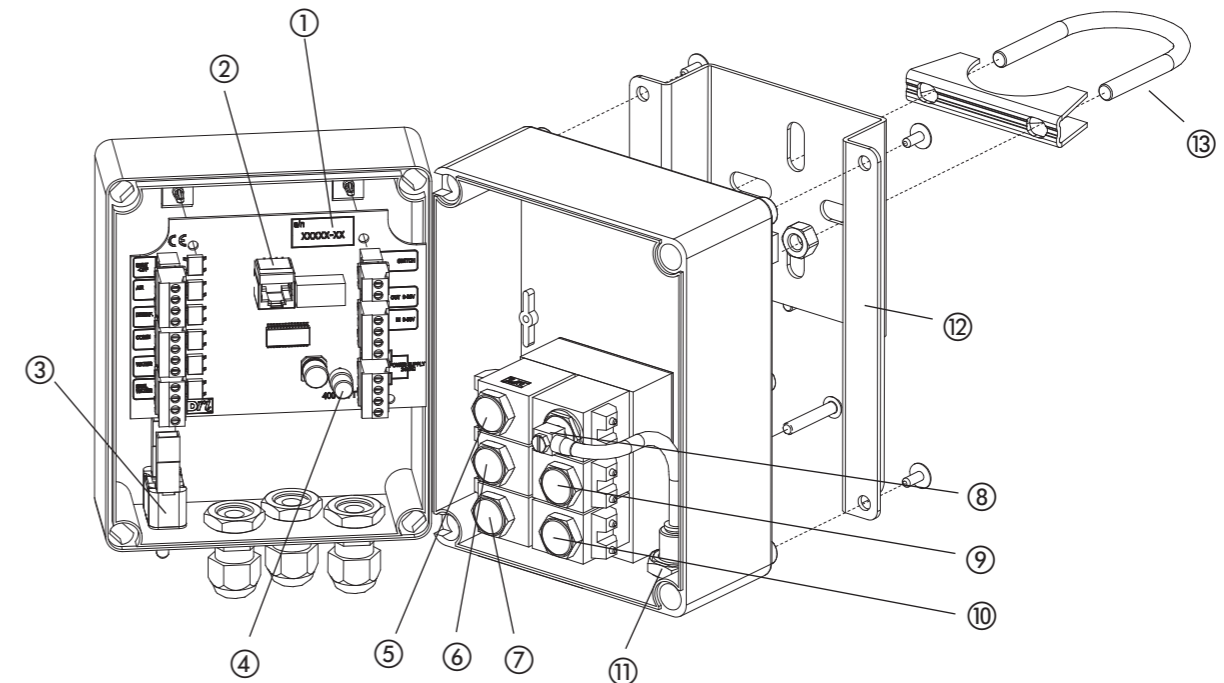
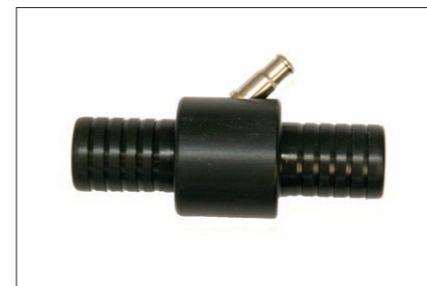

- | | |
|--|-------------------------|
| 1. Serial number | 7. Rinse Operator |
| 2. RJ-45 connector to connect to the AWP Programmer (DRI-8004) | 8. Pinch-valve Operator |
| 3. 400 mA Fuse | 9. Air Operator |
| 4. ON / OFF Toggle switch | 10. Teat Dip Operator |
| 5. Combi Operator | 11. Air Drain |
| 6. Water Operator | 12. Mounting bracket |
| | 13. U-saddle |

At the bottom of the AWP-Gold cabinet are a total of five output ports with different connection diameters and a toggle switch.

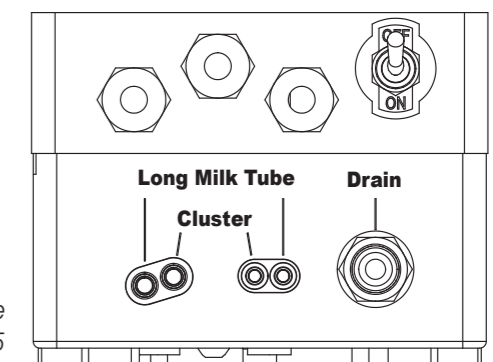

connection at the bottom DRI-3915

Toggle switch - At the bottom of the DRI-3909 AWP-Gold control box is a switch, which can be selected in the ON / OFF position.

ON position: during normal use, this switch is selected in the ON position, but when a fault occurs, the AWP controller can be switched off per milk position, the delay of the take-off signal is also overruled and the ACR signal will be switched off without delay is passed on to the take-off cylinder, allowing “normal” milking.

Long Milk Tube - This connection nipple controls the Pinch valve and the flushing of the long milk tube.
 Plug-in nipple OD 6mm (small) air control Pinch-valve.
 Plug-in nipple OD 8mm (large) medium Rins / Air

Cluster - The AWP end connection DRI-1774 is connected to this connection nipple, which provides the dip and rinsing to the milking claw.

Plug-in nipple OD 6mm (small) medium Dip medium
 Plug-in nipple OD 8mm (large) medium Rins / Air

Drain - Air outlet Pinch-valve, if necessary you can extend the outlet with the proper hose.

Connection Rear

On the back of the AWP-Gold valve box it is written which medium must be connected where.

The following functions are operational:

Teat dip - 8mm push-in connection is for the entry of the Rode 8mm Dip line, DRI-885.

Air - 8mm push-in connection is for the entry of the Blue 8mm air line. DRI-886.

Rinse - 8mm push-in connection is for the input of the Black 8mm Water / Disinfectant, DRI-884.

Water - 8mm push-in connection is for the input of the Transparent 8mm Water, DRI-883.



Wiring diagram

The AWP-Gold control box is supplied with mounting bracket and with 2,5 M color coded (Blue – Brown) 2 x 1.5mm² control power cable.

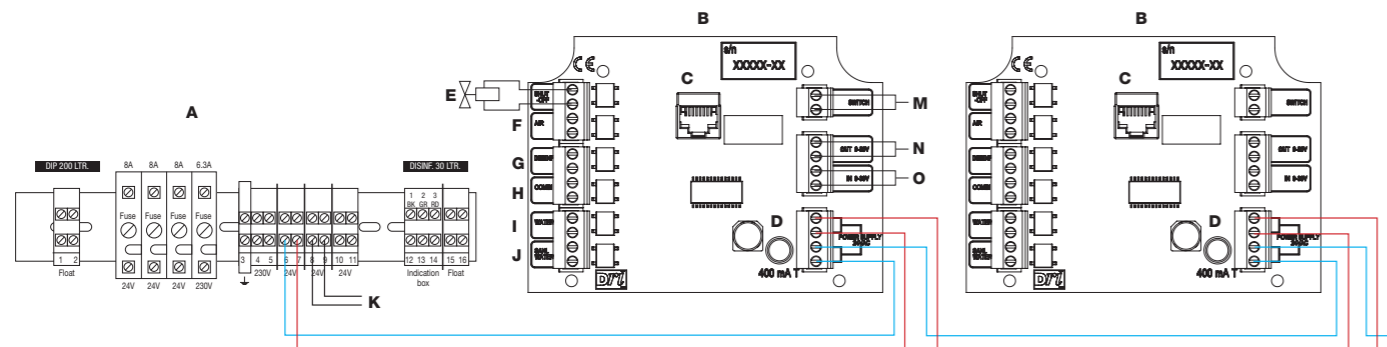

- | | | | |
|---|-------------------------------|---|--------------------------|
| A | Main Controle Unit (DRI-3903) | I | Water-valve |
| B | Controller per Milking point | J | Sanitizer-valve |
| C | RJ-45 Connector | K | Power connection LH side |
| D | Fuse 400mA | L | To next Controller |
| E | Pinch-valve | M | ON/OFF Toggle Switch |
| F | Air-valve | N | Output ACR |
| G | Dip valve | O | Input ACR |
| H | Combi-valve | | |

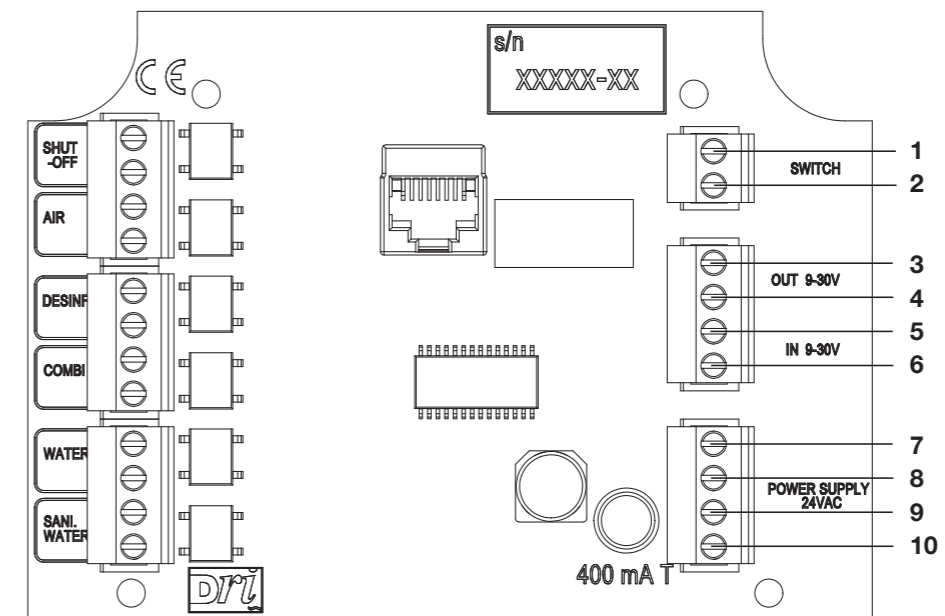

- 1 - 2 Is the connection of the on / off switch which is located at the bottom of the cabinet. With this switch you can turn off the AWP system per milking point when a malfunction occurs. When this switch is selected in the OFF position, the power to the control box is off and the automatic take-off signal (ACR) 5 - 6 is immediately switched to 3 - 4, activating the ACR without delay, resulting in a “normal” milk flow. is possible.
- 3 - 4 Is the delayed or not delayed outgoing signal that goes to the automatic take-off ACR controller. This delay can be set to create the correct dip moment. This signal can vary from 9 VAC / DC to 30 VAC / DC. To achieve this delay, a 4-core control cable must be used.
- 5 - 6 Is the input signal that comes from the ACR and can be passed on with a delay to 3 - 4. This signal can vary from 9 VAC / DC to 30 VAC / DC.
- 7 - 9 Is the connection of the power supply signal of 24VAC which comes from the previous AWP Processing unit (milking point). 7 - Brown and 9 - Blue
- 8 - 10 This connection is equipped with a 1.5 meter control cable that supplies the following AWP Processing Unit (milking point) with power. 8 - Brown and 10 - Blue.

AWP Gold (DRI-3915)

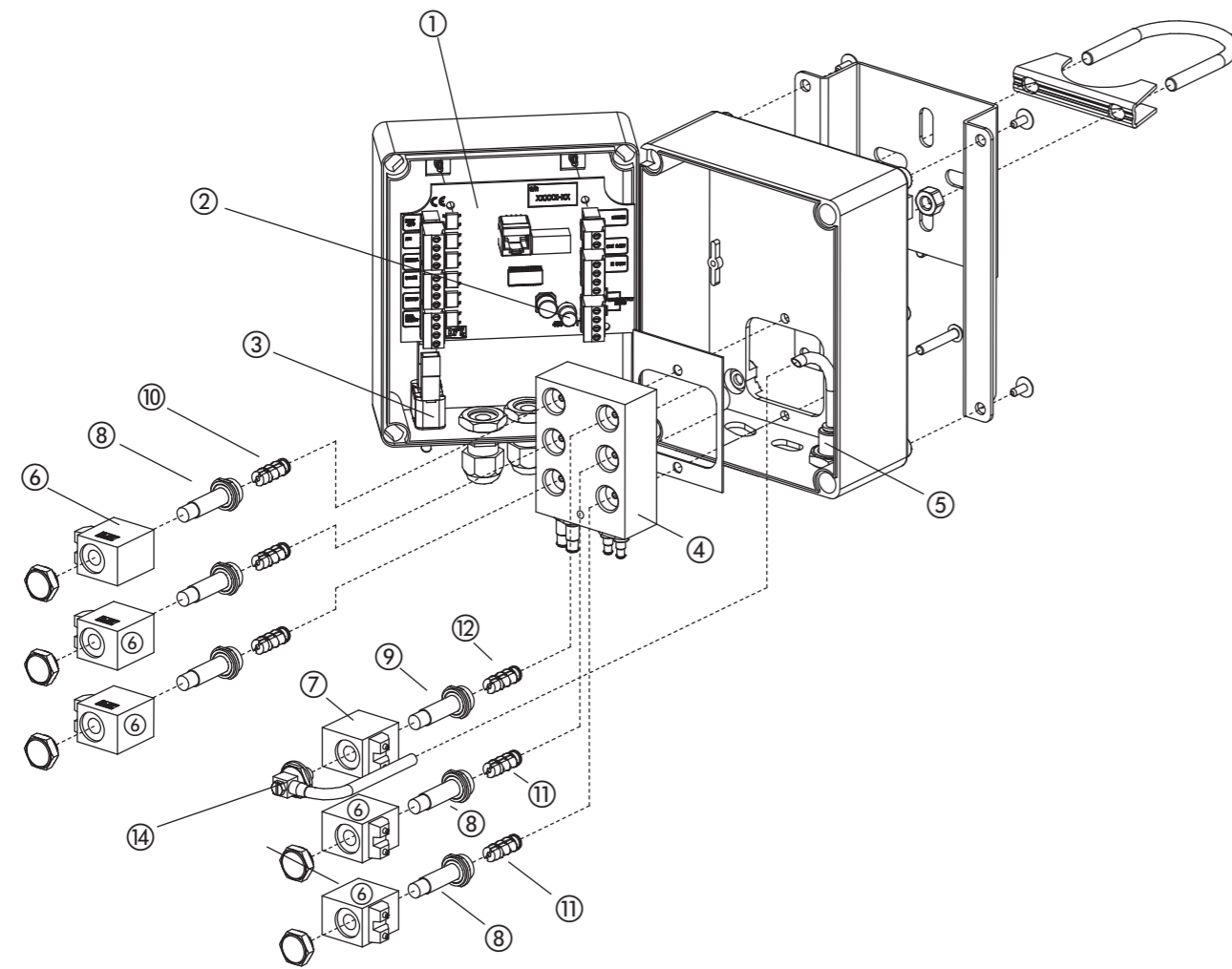

As shown above, all operators are operational with an AWP Gold.

Description	DRI no.
AWP-Gold Proc. Unit per place	DRI-3915
1 PCB	DRI-611
2 Fuse for PCB 400mA	DRI-660
3 Toggle-switch	DRI-620
4 AWP-Regular 6-way Solenoid-valve with operators	DRI-284
5 Bulkhead connector (drain) 6mm	DRI-30
6 Coil for Solenoid-valve	DRI-276
7 Coil for Pinch-valve	DRI-277
8 Stem M14 + O-ring for 2/2-valve	DRI-260
9 Stem M14 + O-ring for 3/2-valve	DRI-262
10 Plunger + Spring (Water/Rins/Combi)	DRI-292
11 Plunger + Spring (Air/Dip)	DRI-291
12 Plunger + Spring (Pinch-valve)	DRI-290
14 90° x M5 Elbow tube connection	DRI-263

AWP End Connection 4m. (DRI-1774)

The hoses used for the AWP system are made of a flexible but very strong quality in order to experience as little disruption as possible during the milking process.

The duo hose which are welded together is the connection where the mediums are transported from the AWP switch box and the AWP injector.

The milk - pulsation and duo hose can be bundled together by means of the: alignment milk-tubing strap DRI-1202.

The thicker hose with a diameter of 8x5mm is for water and air and the thinner hose with a diameter of 6x3mm for the dip agent.

The duo hose comes together in the Y-piece where all mediums transfer into one hose of 6x3mm where later the distribution takes place over the 4 injectors.

In order to use the correct amount of dip agent that is needed for good coverage, a check valve is built into the dip part in the Y-piece.

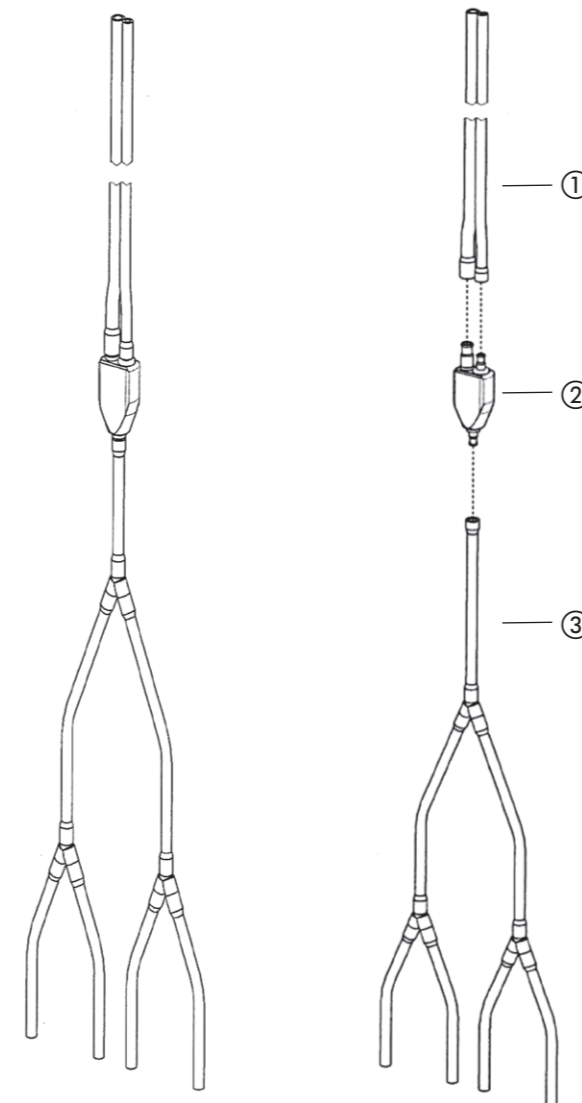

Description	DRI no.
AWP End-Connection 4m	DRI-1774
1 AWP Twin-pipe reel 100M.	DRI-3815
2 AWP Y-joint for twin-pipe	DRI-919
3 AWP End-piece	DRI-1775
4 Alignment milk-tubing Strap	DRI-1202

The AWP system has 3 different sizes of injectors which are mounted in the short milk hose. The 8mm, 10mm and the 12mm. The dimensions shown are the inner size of the injector, which must correspond to the inner size of the short milk hose. The injectors are packed and supplied in a set of 4 pieces.

The AWP injectors are equipped with an integrated check valve, so that during the normal milking process there are no fluctuations in the vacuum. The check valve is opened at an overpressure of at least 1 bar.

All of the injectors are 22.7 mm long in the recess area. We recommend not cutting out this piece. In order not to have a negative effect on the cutout function at the present bend point in the short milk tube and also to prevent air entering the cup sleeve as result of the sealing rim slipping inwards, the positioning of the injector in the short milk tube is very important.

Important

Only cut the short milk tube with a suitable (sharp) hose shears. **Use the Airwash Liner Cutter which is included. Never ever use a knife!** If the cut is not smooth, the ends of the liner may tear. The cut must be at right angles. Only cut the short milk tube after fitting the liner in the shell.

To mount the injector in the short milk hose, you can use the injector mounting spray. This spray makes it easier to assemble and is easy to rinse with clean water and is harmless to public health.

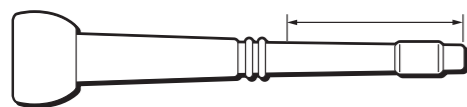

Standard liner.

With the liner already inserted into the shell cut the end piece as close to the cup as possible (see diagram on the left).

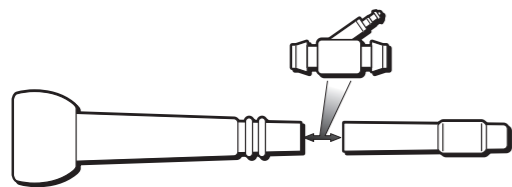

Insert the injector into the liner so that the nozzle is aligned with the pulsation nozzle on the shell.

We advise for installing the injector into the liner to use injector spray, a non-toxic spray on water base.

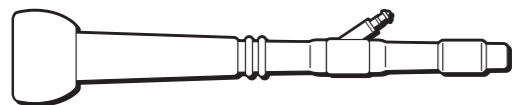

Push the end piece of the liner onto the injector, connect a short pulsation tube to the shells pulsation nozzle.

Be aware that when the injector is placed in the milk liner, this liner will increase lengthwise by 22,7 mm. See example above.

liner shut off function / connection of injector

The bending angle and thus the shut-off function of the liner in the area of the short milk tube may be affected by the length of the short pulsation tubes and the injector hoses. It is therefore important that the bending angle is not restricted by injector hoses which are too short. This is the best way to proceed:

- Hold the cluster in the milking position with the teat cups hanging downwards
- Fit the short pulsation tubes to the cluster nozzles

Now connect the injector connecting pieces with the injector hoses in such a way that they do not touch the pulsation tubes.



TIP It may be necessary not to push the short pulsation tubes completely on to the pulsation nozzles.

In each case, however, the injector hoses must always be pushed on to the injector connecting piece up to the stop.

Attach the milk line to the long milk hose and the pulsator to the long pulsation tubes and then connect the tubes to the cluster.

Note

Do not use silicone spray or similar to reinstall the hose. As a result, the hose will easily come off again.

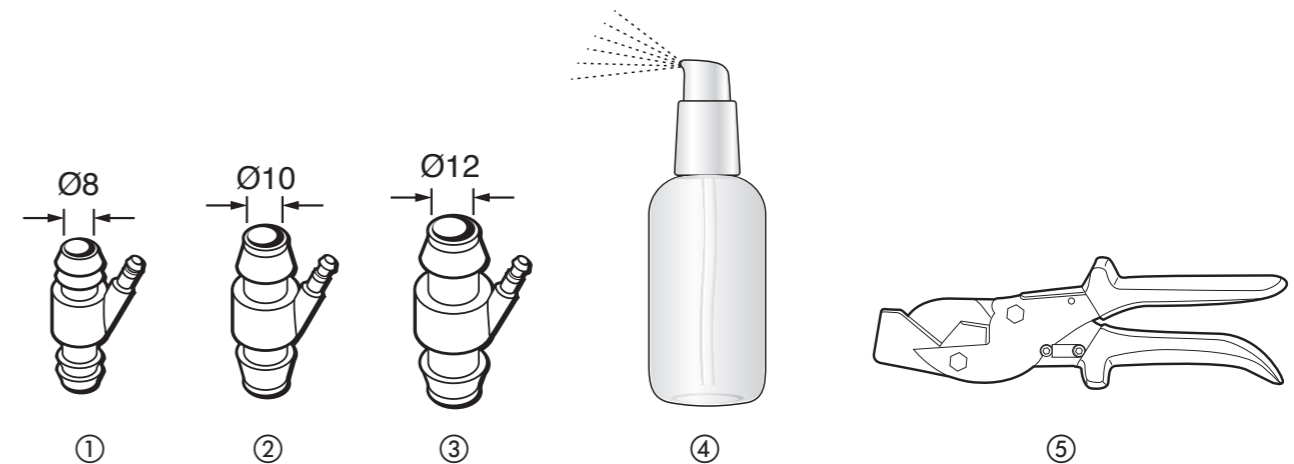

Description

DRI no.

- | | | |
|----|--|----------|
| 1. | AWP Injector 8mm INOX (set) | DRI-526 |
| 2. | AWP Injector 10mm INOX (set) | DRI-522 |
| 3. | AWP Injector 12mm INOX (set) | DRI-524 |
| 4. | AWP Mounting spray for injector 100ml. | DRI-9006 |
| 5. | AirWash Liner Cutter | DRI-2301 |

AWP Programme/Copy Kit (DRI-8004)

This AWP Program / copy kit consisting of 5 components:

1. 7 "Android tablet
2. RJ-45 extension cord
3. Programming cable RS485-USB
4. Read / copy dongle
5. OTG adapter



①

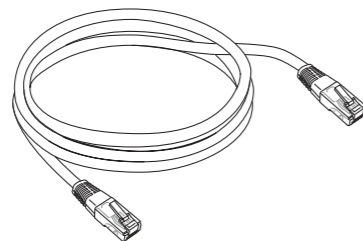

②

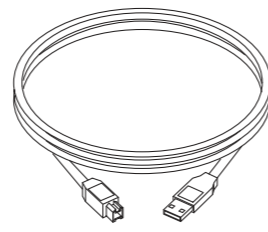

③

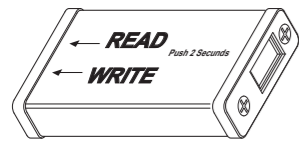

④



⑤

With this 7 "Android tablet (1) you can read and / or change the basic program. The software program UsbTerm which is needed to program the AWP is already installed.

To connect to the AWP control box you need the OTG adapter (5) and the Programming cable RS485-USB (3).

To read and / or change the parameter setting of the AWP system, use the AWP program / copy kit.

Make sure the AWP Tablet is sufficiently charged before you start installing and / or changing the AWP parameters.

AWP control boxes DRI-3908, DRI-3909 and DRI-3915 are pre-programmed with a basic setting from the factory. If this setting is not sufficient, the settings can be changed with the aid of the AWP Tablet, Programming cable RS485-USB and the OTG adapter.

AWP Programming

To access the PCB, open the hinged lid of the AWP control box. Disconnect the 4-way 24VAC **connector (A)** from the PCB so that there is **no** voltage on the AWP PCB.

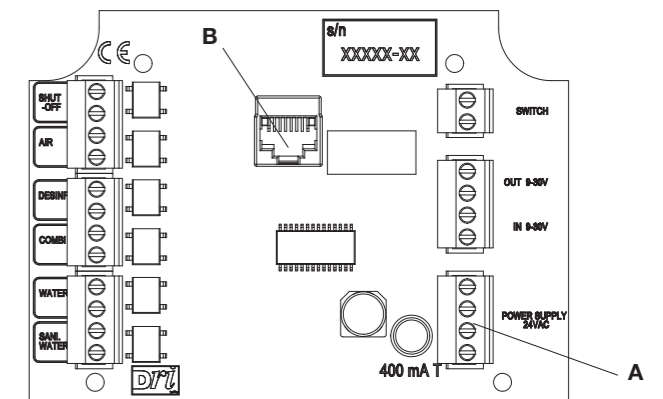

Step-by-step plan to gain access to the AWP program:

- Switch on the tablet with the on / off button which is located on the side of the tablet, the tablet will now start. This can take up to 60 seconds.
- Unlock display by touching the screen (Lock at the bottom of the screen, swipe it up)
- Open the UsbTerm icon by touching the screen.
- Connect connection cables to AWP PCB RJ-45 connector (B). It will now read "Open USB Terminal when this USB device is connected?"
- Check the box to recognize cable "Use by default for use this device" then check OK.
- Tap the screen again to show the keyboard.
- Press enter to open the basic program, now the basic settings parameters are displayed. See Appendix

```

Airwash Plus Programmer v.2.0 Settings
Type : AW30 (TY to change to AW20)
Ident.(ID): NL7241MA66A DRI
Text (TT):
Total counter: 00000 Service counter (SC to reset): 000
00
Service limit (SL) : 10000
Skip first IN (SI) : YES
Delay Out (P2) : 00.0
Delay Shut-Off (P1): 00.0
    
```

SHUT-OFF	DIP	AIR	SANI-TIZER	WATER	COMBI	OUT	TIMER REF.	SETTING (sec.)
[P1]	[P2]	P0	00.0
*	*	*	*	*	*	*	DO	00.7
*	.	*	.	.	.	*	A0	00.8
*	*	P3	05.0
*	.	.	*	.	*	.	P4	02.0
*	.	*	.	.	*	.	S1	03.0
*	.	*	*	.	*	.	A1	01.5
*	.	.	*	.	*	.	S2	04.0
*	.	*	.	.	*	.	A2	01.5
*	.	.	*	.	*	.	S3	04.0
*	.	*	.	.	*	.	A3	01.5
*	.	*	*	.	*	.	S4	00.0
*	.	.	*	.	*	.	A4	00.0
*	.	*	.	.	*	.	S5	00.0
*	.	*	*	.	*	.	A5	00.0
*	.	.	*	.	*	.	S6	00.0
*	.	*	.	.	*	.	A6	00.0
*	.	.	*	.	*	.	S7	00.0
*	.	*	.	.	*	.	A7	00.0
*	*	.	P5	04.0
*	.	*	.	*	*	.	W8	03.0
*	.	.	.	*	*	.	A8	01.5
*	.	*	.	*	*	.	W9	00.0
*	.	.	*	.	*	.	A9	00.0
*	*	*	P6	04.0
.	*	Until no IN	

Parameter to edit (XX):

- LED indicator on PCB will now flash, during this flashing time (+/- 30 sec.) Can change with parameters.
 - You can change 1 line at a time, press ENTER after each change, a new screen will be displayed.
- When times are changed, always enter 3 digits without a comma!

Note: All parameters can be set in time from 0 = 0.00-sec. up to 99.9 sec.

Example:

Adjust dip time in 1.2 sec.

Step 1 Enter. New screen is displayed.

Step 2 enter D0 (= Dip value), (XX) is displayed!

Step 3 New D0 time (prompted) enter 3 desired digits in 012, and ENTER to display new value.

D0 is at 01.2

See example on the previous page.

Explanation of abbreviations:

TY	Type designation AW20 or AW30 (Airwash Plus)
ID	NVT
TT	Identity, one can enter a unique customer name or number. Maximum 16 characters
SC	Service Counter reset. (after service)
SL	Service Limit (set on 10,000 cycles)
SI	Can the first start signal be skipped Y / N (Yes or NO) in connection with the commissioning of the milk system.
P2	Delay of ACR signal forwarding.
P1	Put on zero! Delay Pinch valve
PO	Start delay.
DO	parameter Dip valve.
AO	Parameter Air-valve (Dip-shot)
P3	Pause ACR movement. To bring the milking claw into the normal parking position.
P4	Time to lower the claw. Setting "0" claw remains in parking position.
S1-S7	Parameter Sanitizer Can be repeated a maximum of 7 times, depends on the number of flushes required.
A1-A7	Parameter Air Can be repeated a maximum of 7 times, depends on the number of flushes required.
P5	Sanitizer working time before rinsing with clean water
W8	1st Clean water rinse
A8	Parameter Air
W9	2nd Clean water rinse
A9	Parameter Air
P6	Drip time (0 sec. Advice setting)

Preparation for putting airwash plus into operation

Begin filling the water reservoir with water - the float will stop the water supply once the correct level has been reached.

Place a full container of disinfection under the Dosatron. Install the suction hose into the probe (DRI-1107) and then into the container, ensuring there is a gap of about 2 cm between the end of the hose and the bottom of the container.

Place a full container of teatdip under the AWP Pump & Filter Cabinet. Install the suction hose into the probe (DRI-1106) and then into the container, ensuring there is a gap of about 2 cm between the end of the hose and the bottom of the container.

When the water supply is at the correct level and the containers are installed, open the air supply from the compressor. Both pumps will now be under pressure, as well as the air filter regulator.

At this point, the pressure reduction screw must be at zero or completely turned off. After checking the pressure system, the pressure for the ring circuit may be turned up slowly, care still being taken to ensure there are no leaks. The pump starts to function and the air pressure builds up in the water ring circuit. If water is escaping the pressure should be immediately switched off and the line break sealed. When certain the line is watertight, slowly turn on the pressure regulating valve. First, the valve must be pulled out of the stop position and then turned to the right (inwards) to slowly increase the pressure.

It will now be possible to hear water passing through the ring circuit. Turn the pressure up to a maximum of 2 Bar, then check the system again for leaks, sealing immediately any that are present. If everything is in order the pressure can be increased to approximately 7 Bar.

The control knob must be again secured by pressing it down. This procedure is also applicable for the pump and for the air filter.

Advice

We advise to check for leaks by putting airpressure on each supply line in the ring circuit before putting it in operation. This is easier to check on leakages.

CAUTION

The AirWash Plus system is based on dip in combination with water/air injection. Chemical water additives, apart from those indicated in this manual, are prohibited because they may attack the metal parts.

Service has to be done in:

- ~ 10.000 program runs (service LED)
- or ~ a half year.

In all parlours we advise to:

- Renew all injector tube end pieces
- Renew all injectors
- Renew filter elements
- Check air filter and when necessary, renew both filters
- Empty water reservoir, clean it and fill it again
- Maintenance to compressor according to suppliers instructions

Resetting the service counter

After 10.000 rinses the LED indicator service counter located on the lid of the Airwash Plus control boxes lights up. This is an indication to perform maintenance service.

When maintenance service is performed the service counter can be reset with the Programming kit.

Note!

Make sure the tablet is charged before entering and/or changing the parameters.

Water pump and water filter maintenance

Every 6 months, or sooner according to soiling, the filter insert must be changed.

How to change the water filter

1. Shut off the water supply to the water container.
2. Press the vent valve to release the pressure from the filter housing
2. Start to disconnect the filter bowl from the filter housing. Turn the filter bowl anti-clockwise.
3. Change the filter element for a new one.
4. Replace the filter element and turn the filter bowl clockwise in the filter housing.
Check if the rubber 'O' ring is in good shape.
5. Return the system to pressure by turning the water supply on.

How to change filter elements:

1. Shut off the air supply compressor.
2. Depressurise the AirWash Plus system, by lifting the pressure adjustment knob (A) to unlock and then turning it anti-clockwise. Turn the bowl anti-clockwise (quick disconnect system).
3. Replace the filter element.
4. Clean the reservoir on the inside and install the reservoir again.
5. After installation of the filter element you can put some pressure on the filter set, by turning the pressure adjustment knob clockwise.

Adjust the air pressure with the knob until 0,8 MPa Air pressure can be checked using the pressure gauge. When the air pressure is adjusted correctly push the knob to lock the system.

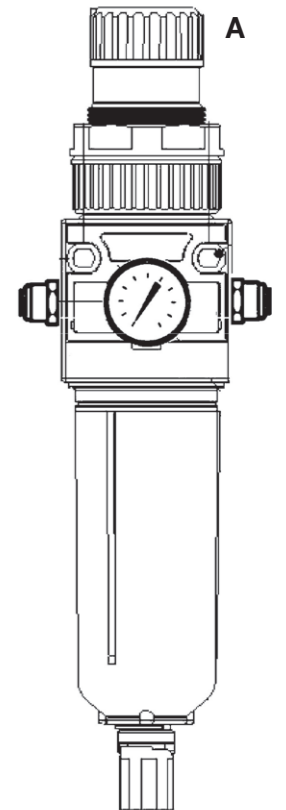

Troubleshooting

Symptom	Cause	Action
Water, dip and air valve do not work properly.	The valves are broken or clogged.	Contact the service technician.
Quantities of water and air are not adequate.	The water/air tubes are damaged or disconnected.	Check whether water and air supply tubes are perforated, bent or distorted.
Compressed air is not adjustable.	The air valve is incorrectly mounted.	Check whether the arrow for the air flow points to the right direction.
There is an inadequate water supply from the tank.	The float is stuck or broken.	Shut off the water supply and clean the area around the float valve.
The water pump pressure control does not switch on.	The power supply is disconnected or insufficient.	Check the power supply.
The water pump pressure control does not switch off.	There is a leakage in the water pipes/tubes.	Check if the suction line is glued well.
The dip pump pressure control does not switch on.	The power supply is disconnected or insufficient.	<ul style="list-style-type: none"> • Check the power supply. • Reset the pump by pressing the button on the left
The dip pump pressure control does not switch off.	There is a leakage in the water pipes/tubes.	<ul style="list-style-type: none"> • Check the power supply. • Reset the pump by pressing the button on the left
Pressure control sign "Failure" lights up.	The water ring circuit is very large.	Press the [Reset] button until the red light has gone out.
	The pump does not pump any water.	Make sure that the water tank is filled and fill the body of the pump.
	The pump is broken.	Check if the body of the pump is fully filled with water.
	The pump is broken.	Remove the body of the pump and inspect the pump (especially the impeller).

Troubleshooting

Symptom	Cause	Action
No water is coming out of all four injectors.	The water valve is mounted incorrectly.	Check if the water valve is installed in correct position (the arrow should point downwards).
Water, dip and air valve do not open.	The valve is connected incorrectly.	Contact the service technician.
Push-in connection is leaking.	<p>The pipe is not properly connected in the push-in coupling.</p> <p>The push-in coupling is damaged.</p> <p>The push-in coupling is not cut in a straight angle or has rough edges.</p> <p>The O-ring is missing or damaged.</p>	<ul style="list-style-type: none"> • Close the water and air supply. • Release the pressure of water and air. • Push the tubing firmly in the coupling. • Check if the secure-clip is damaged. • Check if the O-ring is present and in good condition. • Check if the tubing has been cut straight. • Check the edges of the tubing.
Water, dip and air supply is not sufficient.	There is a leakage in the water pipes/tubes.	Check if water and air tubing is not either bent, twisted or leaking.
There is no 24 V on outgoing signal.	The fuse has blown.	Contact the service technician.
There is an unequal water quantity between the injectors on one cluster.	<p>There is a leakage in the connections.</p> <p>The pressure is set incorrectly.</p> <p>The valve is broken or damaged.</p>	<ul style="list-style-type: none"> • Check if the air pressure is correct (0,8 MPa on the manometer on air filter element). • Check if the water pressure regulator off at 0,45 MPa (the manometer on the water pump). • Check if the valve inside the injector functions correctly. • If necessary replace all four injectors.

Symptom	Cause	Action
There is no water, dip and air coming from one or several clusters.	<p>There is a leakage in the connections.</p> <p>The pressure is set incorrectly.</p> <p>The valve is broken or damaged.</p> <p>There is an electrical disconnection.</p>	<ul style="list-style-type: none"> • Check if the air pressure is correct (0,8 MPa on the manometer on air filter element). • Check if the water pump switches off at 4.5 bar (the manometer on the water pump). • Check if the water and air ring circuit is bent or twisted. • If the problem persists, contact the service technician.
There is no water and air on one side of the parlour.	There is a problem with the electrical connection between the involved units.	Contact the service technician

SYMPTOM	CAUSE	SOLUTION
Motor piston		
DOSATRON does not start or stops	Piston stalled	Reset piston by hand
	Air has not been bled from unit	Bleed air from unit, by bleed button
	Maximum flow exceeded	<ol style="list-style-type: none"> 1. Reduce flow, restart unit 2. Unscrew the top cap Take off the piston and check piston valves seals to ensure correct position
	Motor piston is damaged	Return unit to your service centre for repair
Injection		
Water flowing back into concentrate container	Contaminated, worn, or missing check valve parts	Clean or replace it
No suction of concentrate	Air leak (inlet) in the suction tube	Check the tightness between nut and suction hose
	Blocked suction tube or clogged strainer	Clean or replace it
	Missing or worn suction check valve seal	Clean or replace it
	Missing or worn plunger seal	Clean or replace it
	Worn injection stem	Replace it
Under injection	Suction of air	<ol style="list-style-type: none"> 1. Check the tightness of the nuts in the injection area 2. Check suction tube
	Dirty or worn check valve seal	Clean or replace it
	Maximum flow exceeded (cavitation)	Reduce flow
	Worn plunger seal	Replace it
	Worn injection stem	Replace it
Leaks		
Leaks in the vicinity of the fixing ring under the body housing	Injector sleeve seal is damaged or positioned incorrectly	Replace it
Leaks between the setting sleeve and the blocking ring	Injector stem seal damaged, positioned incorrectly or missing	Replace it
Leaks between the body and screw-top	Screw-top seal is damaged, positioned incorrectly or missing	Unscrew the screw-top, clean the seal seating, replace or change the seal.



Dutch Research & Innovations

Aalsvoort 66 a • 7241 MA Lochem • The Netherlands
dri@airwash.info • www.airwash.info